



Soluciones de montaje



REAL TOOLS FOR REAL WORK.™

Símbolos técnicos

	Herramientas eléctricas		Altura de cabezal angular		Longitud de herramienta
	Capacidad máx. de portabrocas/pinza		Longitud de husillo flotante		
	Remachado		Carrera de husillo flotante		
	Par crítico		Capacidad de perno		
	Máx. velocidad libre		Margen de pares		Portapuntas
	Altura de elevación estándar		Margen máx. de pares		
	Peso de la herramienta		Margen de pares con resorte de embrague ligero		
	Capacidad de carga nominal		Margen de pares con resorte de embrague medio		
	Radio del cilindro		Margen de pares con resorte de embrague pesado		Distancia del lateral al centro
	Diámetro de adaptador		Llave de portabrocas		
	Diámetro de adaptador de conexión		Mango		
	Manguera espiral estirada		Longitud de carrera de pistón		
	Manguera espiral sin estirar		Altura de carrera de pistón		Presión de filtro
	Máx. consumo de aire		Tamaño de conexión neumática		Filtro
	Rosca de conexión		Lijadora de banda		Longitud de tubo
	Pantalla		Comunicación		
	Voltaje				



Hexágono de cambio rápido (para puntas eléctricas)

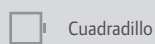

Cuadrado



Portapuntas hexagonal (solo para puntas eléctricas)



Portapuntas hexagonal (necesita guía para puntas o casquillo centrador)



Portapuntas hexagonal para puntas de inserción (para puntas de inserción de 25 mm)

Selección de embrague

Transductor

Un transductor convierte los datos de tensión en datos de par. El control de par, ángulo y velocidad con transductor proporciona una excelente precisión además de trazabilidad, y hace posibles diversas configuraciones, así como control de bucle cerrado verdadero.



Embrague ajustable con parada automática de precisión

Diseñado para operaciones críticas de atornillado en plásticos, materiales compuestos o metales. Recomendados para aplicaciones que exigen un control del par preciso. La función de parada automática reduce el consumo de aire. Los parámetros de par se pueden ajustar fácilmente sin desmontar la herramienta.

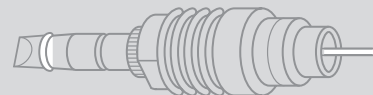

Embrague amortiguado ajustable

Un excelente embrague de uso general. El mecanismo de embrague amortiguado cuenta con un máximo de 24 esferas de acero que proporcionan una suave acción rodante que mejora el control del par, prolonga la vida útil del embrague y minimiza la vibración para el operario y la pieza de trabajo.

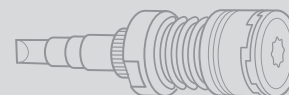

Embrague positivo de mordazas

Diseñado para aplicaciones en las que el par inicial puede exceder el par final de asentamiento. Está recomendado para aplicaciones en madera y autorroscantes, donde el par necesario varía. El par aplicado está controlado por el operario y la potencia del motor; el par de salida se puede limitar regulando la presión de la tubería neumática.

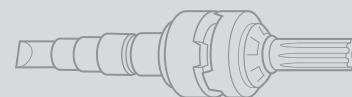

Transmisión directa

Diseñada para aplicaciones de apriete suave en madera y otros materiales que no requieran control de par crítico. El par aplicado está controlado por el operario y la potencia del motor; el par de salida se puede limitar regulando la presión de la tubería neumática.

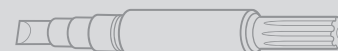

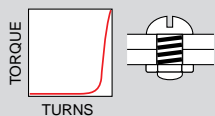
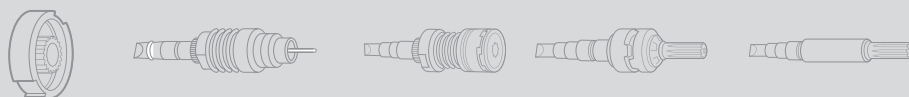

Máximo repentino de aceleración

La resistencia es baja durante el arranque y el aflojado, pero alcanza el máximo de repente al asentarse la cabeza del tornillo.

**** * * * *

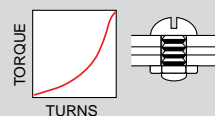

Juntas de compresión

La resistencia de giro va aumentando gradualmente conforme la presión se acerca al último giro.

**** * * * *

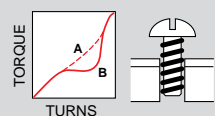

Tornillos autorroscantes

La resistencia inicial es alta durante el recorrido del roscado, y va disminuyendo hasta que tiene lugar una subida repentina (B) o gradual (A) al asentarse.

**** * * * * * * * * -

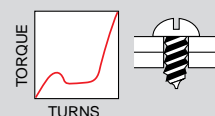

Tornillos para chapa metálica

El par de arranque va aumentando hasta que tiene lugar la penetración, y después disminuye la resistencia hasta que se asienta la cabeza.

**** ** ** * * * * *

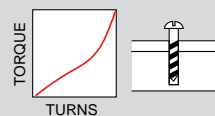

Tornillos para madera

La baja resistencia inicial aumenta gradualmente durante el apriete hasta que la cabeza queda asentada.

**** - ** * * * * *



Atornilladores neumáticos

Ingersoll Rand ofrece una línea completa de equipos de atornillado para producción, incluidos atornilladores neumáticos, aprietatuercas y sistemas fijos en una amplia variedad de configuraciones. Tanto si necesita una solución para una sola aplicación concreta como para toda una línea de montaje, podrá confiar en nuestra experiencia de más de un siglo en diseño de herramientas para proporcionarle unas herramientas no solo lo bastante duraderas para sus aplicaciones más difíciles y de gran volumen, sino también con toda la velocidad y la precisión que necesita. Nuestra amplia línea de productos le ofrece la flexibilidad necesaria para poder elegir la solución exacta que mejor se adapte a su aplicación y maximice la productividad.



Atornilladores neumáticos



De pistola

Embrague amortiguado ajustable	61
Embrague ajustable con parada automática	62
Transmisión directa	63
Embrague positivo de mordaza	64



Angulares

Embrague amortiguado ajustable	65
Embrague ajustable con parada automática	66
Transmisión directa	68



En línea

Embrague amortiguado ajustable	69
Embrague ajustable con parada automática	70
Transmisión directa	72

Accesorios	73
-------------------	-----------

Atornilladores neumáticos

Información de la serie

Serie 1

Diseño de trayectoria demostrada que proporciona resultados repetibles a un precio económico

- Margen de pares: 0,3 - 5,2 Nm
- Velocidad: 500 - 2800 r. p. m.
- Compactos y ligeros
- Empuñadura revestida para mayor comodidad del operario



1RAMC1



1RLM2S5



1RLMC1

Serie 41

Diseño de trayectoria demostrada, conocido por su gran durabilidad y rendimiento

- Margen de pares: 1,1 - 14,7 Nm
- Velocidad: 600 - 2500 r. p. m.
- Mando de inversión de giro de fácil manejo con una sola mano
- Control preciso del par en un formato silencioso y ergonómico



41PC10TSQ4-EU



41AA6LTS6-EU



41SC10LTQ4-EU

Serie 5

Durabilidad y rendimiento

- Margen de pares: 1,5 - 12,5 Nm
- Velocidad: 900 - 2000 r. p. m.
- Calidad y durabilidad demostradas



5RANC1-EU



5RLN2C6-EU

Atornilladores neumáticos

Información de la serie

Serie 7

Durabilidad y rendimiento

- Margen de pares: 1,7 - 29,9 Nm
- Velocidad: 500 - 1700 r. p. m.
- Calidad y fiabilidad demostradas



7RAMC1-EU



7RLL2C6-EU

Serie 9

Durabilidad y rendimiento

- Par: 111,5 Nm
- Velocidad: 300 r. p. m.
- Cómodo botón de inversión de giro
- Calidad y fiabilidad demostradas
- Control del par mediante regulación de la presión o control del operario



9RSQ83-EU

Serie BALD

Aprietatuercas de alta precisión

- Margen de pares: 1 - 31 Nm
- Velocidad: 140 - 1200 r. p. m.
- Diseño modular para un mantenimiento sencillo y económico
- Salida de señal opcional para el control de ciclos (kit doble de información: añadir «-DI» a la referencia del modelo)
- Apriete de alta calidad mediante un control preciso del par



BALD1202RD5-R18-S4

Atornilladores neumáticos

Información de la serie

Serie LD

Atornillador de alta precisión

- Margen de pares: 0,6 - 15 Nm
- Velocidad: 180 - 1700 r. p. m.
- Compactos y ligeros
- Gatillo rápido de inversión de giro
- Diseño modular para un mantenimiento sencillo y económico
- Salida de señal opcional para el control de ciclos (kit doble de información: añadir «-D» a la referencia del modelo)
- Atornillador con bajo coste de mantenimiento
- Apriete de alta calidad mediante un control preciso del par



LD1202RP5-Q4-RM



LD1202RD5

Serie Q2

Establece un nuevo baremo en herramientas de montaje ergonómicas

- Margen de pares: 0,3 - 11,6 Nm
- Velocidad: 250 - 2000 r. p. m.
- Diseño compacto, ligero y equilibrado
- Entradas de aire superiores e inferiores para un montaje óptico con modelos tipo pistola
- Función de ajuste de la velocidad mediante el escape en los modelos angulares y rectos
- La carcasa ahuecada se ajusta de forma natural a los modelos en línea
- Los números de referencia empiezan por QP1, QA1 o QS1, según la forma



QP1T10C1TD



QA1L05C1LD



QS1T20C1D

Serie QA

La precisión se combina con la durabilidad y la flexibilidad para maximizar la productividad

- Margen de pares: 5 - 225 Nm
- Velocidad: 90 - 1025 r. p. m.
- El embrague ajustable con parada automática proporciona repetibilidad que mejora la calidad de las juntas
- La parada rápida y precisa limita la dispersión y el par de reacción
- Motor sin lubricantes
- Empuñadura ergonómica para mayor comodidad del operario
- Recomendado para aplicaciones en las que se requiera control de par preciso



QA4AALS011BP25S06



QA4ASLS012BP20S04

Atornilladores neumáticos

De pistola

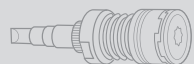
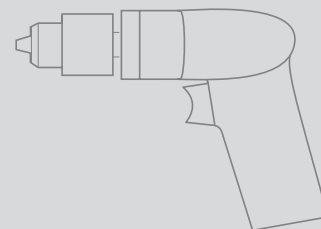

Adjustable cushion clutch





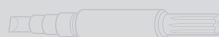







Adjustable shut-off clutch



Direct drive



Positive jaw clutch

Ref.	CCN	 Nm	 Nm	 Nm		 r. p. m.	 kg	 mm	 mm	 pulgadas	 l/s
ARRANQUE POR GATILLO + EMPUJE											
QP1T15C1TD	01383405	0,3 - 1,1	0,9 - 3,1		M4	1500	0,84	223	15	1/4" Ⓞ	7,5
QP1T10C1TD	01383413	0,3 - 1,1	0,9 - 2,5	1,5 - 4,5	M5	1000	0,84	223	15	1/4" Ⓞ	7,5
ARRANQUE POR GATILLO											
1RANC1	04724514	0,3 - 1,8	0,5 - 2,6	1,1 - 3,4	M4	1000	0,68	217	17	1/4" Ⓞ	6,1
1RAMC1	04724506	0,5 - 1,8	0,7 - 2,3		M3	1650	0,68	217	17	1/4" Ⓞ	6,1
QP1S15C1TD	45602349	0,3 - 1,1	0,9 - 3,1		M4	1500	0,84	223	15	1/4" Ⓞ	7,5
QP1S10C1TD	01383512	0,3 - 1,1	0,9 - 2,5	1,5 - 4,5	M5	1000	0,84	223	15	1/4" Ⓞ	7,5
QP1S05C1TD	01383520	0,3 - 1,1	0,9 - 3,2	1,5 - 5,4	M5	500	0,84	223	15	1/4" Ⓞ	7,5
5RANC1-EU	01337740	1,5 - 6,2	6,2 - 8		M6	900	1,30	241	21	1/4" Ⓞ	8
41PC17TSQ4-EU	01341445	1,7 - 4,5	1,7 - 6		M5	1700	1,40	239	20	1/4" Ⓞ	9,4
41PC10TSQ4-EU	01341437	1,7 - 4,5	1,7 - 9		M6	1000	1,40	239	20	1/4" Ⓞ	9,4
7RAMC1-EU	01338367	2,3 - 9,7	2,9 - 12,5		M6	1000	1,50	268	22	1/4" Ⓞ	12,7
41PC8TSQ4-EU	01340033	1,7 - 4,5	1,7 - 9	5,1 - 11,3	M6	800	1,40	239	20	1/4" Ⓞ	9,4

Especificaciones a 6,2 bares (90 psi)

Atornilladores neumáticos

De pistola

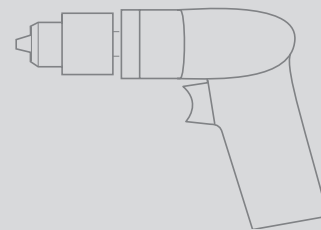

Adjustable cushion clutch

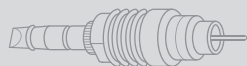

Adjustable shut-off clutch

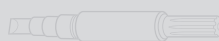

Direct drive



Positive jaw clutch

Ref.	CCN	Nm	Nm	Nm	Nm	r. p. m.	kg	mm	mm	pulgadas	l/s
ARRANQUE POR GATILLO + EMPUJE											
1RTNS1	04724464	0,3 – 1,8	0,5 – 2,6	1,1 – 3,4	M4	1000	0,68	217	17	¼" ⌀	6,1
1RTMS1	04724456	0,5 – 1,8	0,7 – 2,3		M3	1650	0,68	217	17	¼" ⌀	6,1
QP1T20S1TD	01383249	0,3 – 1,1	0,9 – 2,5		M3	2000	0,84	223	15	¼" ⌀	7,5
QP1T15S1TD	45602455IRI	0,3 – 1,1	0,9 – 3,1		M4	1500	0,84	223	15	¼" ⌀	7,5
1RTQS1	04724472	0,3 – 1,8	0,5 – 2,6	1 – 5,1	M5	500	0,68	222	17	¼" ⌀	6,1
QP1T10S1TD	01383264	0,3 – 1,1	0,9 – 2,5	1,5 – 4,5	M5	1000	0,84	223	15	¼" ⌀	7,5
QP1T02S1TD	01389535IRI	0,3 – 1,1	0,9 – 3,2	1,5 – 5,4	M5	250	0,84	223	15	¼" ⌀	7,5
QP1T05S1TD	01383272	0,3 – 1,1	0,9 – 3,2	1,5 – 5,4	M5	500	0,84	223	15	¼" ⌀	7,5
41PA16TPQ4-EU	01340660	1,7 – 4,5	2,8 – 6,8		M5	1600	1,40	249	22	¼" ⌀	13,2
41PA10TPQ4-EU	01342567	1,7 – 4,5	2,8 – 6,8	4 – 9	M5	1000	1,40	249	22	¼" ⌀	13,2
41PA8TPQ4-EU	01338557	1,7 – 4,5	2,8 – 6,8	4 – 11,3	M6	800	1,40	249	22	¼" ⌀	13,2
ARRANQUE POR GATILLO											
LD1207RP5-Q4-RM	53560553	0,6 – 1,6			M2	900	1	210	20	¼" ⌀	7,8
QP1S20S1TD	01383348	0,3 – 1,1	0,9 – 2,5		M3	2000	0,84	223	15	¼" ⌀	7,5
QP1S15S1TD	45602414	0,3 – 1,1	0,9 – 3,1		M4	1500	0,84	223	15	¼" ⌀	7,5
LD1214RP5-Q4	53553913	1 – 2,5			M3	1700	1	220	20	¼" ⌀	7,2
QP1S10S1TD	01383363	0,3 – 1,1	0,9 – 2,5	1,5 – 4,5	M5	1000	0,84	223	15	¼" ⌀	7,5
QP1S02S1TD	49817919	0,3 – 1,1	0,9 – 3,2	1,5 – 5,4	M5	250	0,84	223	15	¼" ⌀	7,5
QP1S05S1TD	01383371	0,3 – 1,1	0,9 – 3,2	1,5 – 5,4	M5	500	0,84	223	15	¼" ⌀	7,5
LD1207RP5-Q4	04367439	1,6 – 4,5			M5	900	1	210	20	¼" ⌀	7,8
LD2216RP5-Q4	04370219	1,8 – 3,8			M4	1600	1,20	250	20	¼" ⌀	8,7
LD2210RP5-Q4	04367520	2,1 – 5,7			M5	1000	1,20	231	20	¼" ⌀	8,7
LD2206RP5-Q4	04367496	2,3 – 9,3			M6	600	1,20	250	20	¼" ⌀	9,6
LD1202RP5-Q4	04367405	2,4 – 9,2			M6	190	1,10	230	20	¼" ⌀	7,8
41PA10TSQ4-EU	01342187	1,7 – 4,5	2,8 – 6,8	4 – 9	M3	1000	1,40	249	22	¼" ⌀	13,2
41PA8TSQ4-EU	01340470	1,7 – 4,5	2,8 – 6,8	4 – 11,3	M4	800	1,40	249	22	¼" ⌀	13,2
LD2203RP5-S6	53444634	10 – 15			M8	300	1,30	271	20	⅜" □	8,7

Especificaciones a 6,2 bares (90 psi)

Atornilladores neumáticos

De pistola

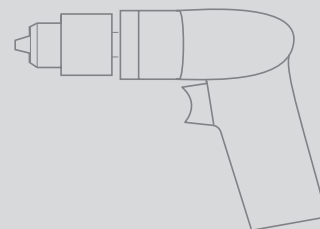

Adjustable cushion clutch





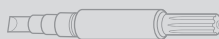











Adjustable shut-off clutch



Direct drive



Positive jaw clutch

Ref.	CCN	 Nm	 r. p. m.	 kg	 mm	 mm	 pulgadas	 l/s	
ARRANQUE POR GATILLO									
QP1S20D1TD	01383546	2,9	M3	2000	0,68	162	15	1/4" 	7,5
QP1S15D1TD	45602372	3,4	M4	1500	0,68	162	15	1/4" 	7,5
5RALD1-EU	01340587	4	M4	2000	0,85	184	21	1/4" 	8
QP1S10D1TD	01383561	5,2	M5	1000	0,68	162	15	1/4" 	7,5
41PD17TSQ4-EU	01342484	7,3	M6	1700	1	188	20	1/4" 	9,4
5RAND1-EU	01338490	8	M6	900	0,95	203	21	1/4" 	8
QP1S05D1TD	01383579	9,8	M6	500	0,68	162	15	1/4" 	7,5
41PD8TSQ4-EU	01342807	13,6	M8	800	1	188	20	1/4" 	9,4

Especificaciones a 6,2 bares (90 psi)

Atornilladores neumáticos

De pistola

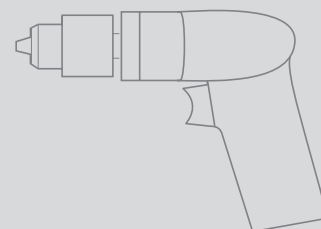

Adjustable cushion clutch





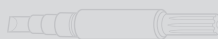



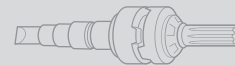







Adjustable shut-off clutch



Direct drive



Positive jaw clutch

Ref.	CCN	 Nm	 r. p. m.	 1 min	 kg	 mm	 mm	 pulgadas	 l/s
ARRANQUE POR GATILLO									
41PP25TSQ4-EU	01339829	5,1	M5	2500	1	183	20	¾" 	9,4
41PP17TSQ4-EU	01340686	7,3	M6	1700	1,10	193	20	¾" 	9,4
5RANP1-EU	01338573	8	M4	900	1	203	21	¾" 	8
7RANP1-EU	01341387	13,1	M5	1000	1,40	237	22	¾" 	12,7
41PP8TSQ4-EU	01341296	13,6	M8	800	1,10	193	20	¾" 	9,4
7RANP1-EU	01340017	18,8	M8	700	1,40	237	22	¾" 	12,7

Especificaciones a 6,2 bares (90 psi)

Atornilladores neumáticos

Angulares

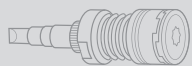
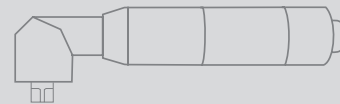







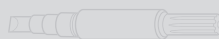







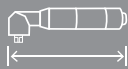



Adjustable cushion clutch



Adjustable shut-off clutch



Direct drive

Ref.	CCN	 Nm	 Nm	 Nm	 r. p. m.	 kg	 mm	 mm	 mm	 pulgadas	 l/s
ARRANQUE POR PALANCA											
QA1L12C1LD	01380286	0,4 - 1,3	1,1 - 3,7		1270	0,95	302	34	13	1/4" 	0
5RLN2C6-EU	01338359	1,7 - 9,1	5,7 - 12,5		600	1,50	334	33	13	3/8" 	8
7RL2C6-EU	01340371		1,7 - 11,3		1400	1,50	335	33	13	3/8" 	12,7
QA1L08C1LD	01380351	0,4 - 1,3	1,1 - 3,8	1,8 - 5,3	850	0,95	302	34	13	1/4" 	0
QA1L08C4LD	01380294	0,4 - 1,3	1,1 - 3,8	1,8 - 5,3	850	0,95	302	34	13	1/4" 	0
QA1L05C1LD	01380369	0,4 - 1,3	1,1 - 3,8	1,8 - 6,4	500	0,95	302	34	13	1/4" 	0
QA1L05C4LD	01380385	0,4 - 1,3	1,1 - 3,8	1,8 - 6,4	500	0,95	302	34	13	1/4" 	0
7RL3C6-EU	01339597		2,8 - 12,5		1400	2,20	363	38	18	3/8" 	12,7
7RLM3C6-EU	01340090		2,8 - 14,8		800	2,30	363	38	18	3/8" 	12,7

Especificaciones a 6,2 bares (90 psi)

Atornilladores neumáticos

Angulares

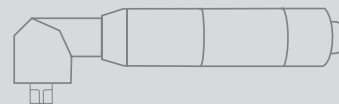

Adjustable cushion clutch

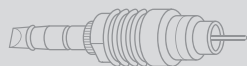

Adjustable shut-off clutch

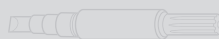

Direct drive

Ref.	CCN	Nm	Nm	Nm	Nm	r. p. m.	kg	mm	mm	mm	pulgadas	l/s
ARRANQUE POR PALANCA												
1RLN2S3	04724522	0,4 - 2,6	0,8 - 3,9	1,1 - 5,2	M5	700	0,79	318	31	13	1/4"	6,1
1RLN2S5	80094998	0,4 - 2,6	0,8 - 3,9	1,1 - 5,2	M5	700	0,79	318	33	13	1/4"	6,1
1RLM2S5	04725206	0,6 - 2,6	0,9 - 3,4		M4	1100	0,79	318	33	13	1/4"	6,1
BALD1202RD5-R18-S4-RM	53424164	1 - 2				140	1	315	23	9	1/4"	7,7
QA1L12S1LD	01384817	0,4 - 1,3	1,1 - 3,7			1270	0,95	302	34	13	1/4"	0
QA1L12S4LD	01379098	0,4 - 1,3	1,1 - 3,7			1270	0,95	302	34	13	1/4"	0
QA1L12S4SD	01382381	0,4 - 1,3	1,1 - 3,7			1270	0,85	299	27	10	1/4"	0
QA1L05S4SD	01379031	0,4 - 1,3	1,1 - 4,1			500	0,85	299	27	10	1/4"	0
BALD1214RD5-R25-H4	04367744	1,4 - 4				1200	1	284	31	13	1/4"	7,7
BALD1207RD5-R25-H4	04367702	1,4 - 5,7				650	1	275	31	13	1/4"	7,7
BALD1207RD5-R25-S4	53558425	1,4 - 5,7				650	1	275	31	13	1/4"	7,7
BALD1207RD5-R25-S6	53558524	1,4 - 5,7				650	1	275	31	13	3/8"	7,7
BALD1207RD5-R18-S4	53616991	1,8 - 4,9				650	1	303	23	9	1/4"	7,7
QA1L08S1LD	01384809	0,4 - 1,3	1,1 - 3,8	1,8 - 5,3		850	0,95	302	34	13	1/4"	0
QA1L08S4LD	01379122	0,4 - 1,3	1,1 - 3,8	1,8 - 5,3		850	0,95	302	34	13	1/4"	0
QA1L08S6LD	01379668IRI	0,4 - 1,3	1,1 - 3,8	1,8 - 5,3		850	0,95	302	34	13	3/8"	0
QA1L02S1LD	89941793	0,4 - 1,3	1,1 - 3,8	1,8 - 6,4		250	0,95	302	34	13	1/4"	0
QA1L02S6LD	01379643	0,4 - 1,3	1,1 - 3,8	1,8 - 6,4		250	0,95	302	34	13	3/8"	0
QA1L05S1LD	01384791	0,4 - 1,3	1,1 - 3,8	1,8 - 6,4		500	0,95	302	34	13	1/4"	0
QA1L05S4LD	01379023	0,4 - 1,3	1,1 - 3,8	1,8 - 6,4		500	0,95	302	34	13	1/4"	0
QA1L05S6LD	01379650	0,4 - 1,3	1,1 - 3,8	1,8 - 6,4		500	0,95	302	34	13	3/8"	0
BALD2206RD5-R25-H4	04382594	2,2 - 12				560	1,30	314	31	13	1/4"	10,8
BALD2206RD5-R25-S4	53557682	2,2 - 12				560	1,30	314	31	13	1/4"	10,8
BALD2206RD5-R25-S6	04367751	2,2 - 12				560	1,30	314	31	13	3/8"	10,8
BALD1202RD5-R18-S4	53619136	2,6 - 9				140	1	315	23	9	1/4"	7,7
BALD1202RD5-R25-H4	04367686	2,6 - 9,4				140	1	287	31	13	1/4"	7,7
41AA9LTS6-EU	01341478	2,8 - 6,6	2,8 - 10,2			950	1,80	361	38	15	3/8"	14,5
BALD2203RD5-R28-S6	04362331	2,8 - 31				170	1,80	399	32	14	3/8"	10,8
BALD2210RD5-R25-S6	04367777	3,2 - 7,5				900	1,30	314	31	13	3/8"	10,8
QA1L05S1XLD	49818032	1,4 - 4,3	3,5 - 10			500	1,03	329	34	13	1/4"	0
QA1L05S6XLD	01380427	1,4 - 4,3	3,5 - 10			500	1,03	329	34	13	3/8"	0
QA1L02S1XLD	49817935	1,4 - 4,3	3,5 - 11,5			250	1,03	329	34	13	1/4"	0
QA1L02S6XLD	01380104IRI	1,4 - 4,3	3,5 - 11,5			250	1,03	329	34	13	3/8"	0
41AA6LTS6-EU	01340074	2,5 - 5,8	2,5 - 9,1	4 - 14,7		600	1,80	361	48	16	3/8"	14,5

Atornilladores neumáticos

Angulares

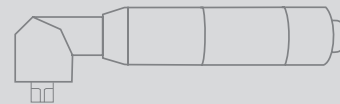

Adjustable cushion clutch



Adjustable shut-off clutch

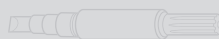

Direct drive

Ref.	CCN	Nm	Nm	Nm	Nm	r. p. m.	kg	mm	mm	mm	pulgadas	l/s
QA4AALS011BP25S06	80156060	5 – 11				1025	1,44	342	33	13	3/8"	12,8
QA4AALS015BP25S06	80156078	7 – 15				800	1,44	342	33	13	3/8"	12,8
QA4AALS020BP25S06	80156169	10 – 20				625	1,44	342	33	13	3/8"	12,8
QA4AALS030BP28S06	80156219	15 – 30				425	1,52	363	35	14	3/8"	12,8
QA6AALS030BP35S06	80186497	15 – 30				580	2,29	429	44	18	3/8"	17
QA4AALS040BP35S06	80156268	20 – 40				325	1,81	395	44	18	3/8"	12,8
QA6AALS040BP35S06	80186505	20 – 40				430	2,29	429	44	18	3/8"	17
QA8AALS040BP35S06	80186554	20 – 40				570	2,44	453	44	18	3/8"	21,7
QA4AALS055BP35S08	80156318	25 – 55				200	2,04	418	44	18	1/2"	12,8
QA6AALS055BP35S08	80186521	25 – 55				320	2,30	429	44	18	1/2"	17
QA8AALS055BP35S08	80186570	25 – 55				425	2,45	453	44	18	1/2"	21,7
QA6AALS070BP43S08	80186539	35 – 70				225	2,30	422	45	22	1/2"	17
QA8AALS070BP43S08	80186588	35 – 70				320	2,45	445	45	22	1/2"	21,7
QA6AALS090BP43S08	80186547	45 – 90				185	2,30	422	45	22	1/2"	17
QA8AALS090BP43S08	80186596	45 – 90				255	2,45	445	45	22	1/2"	21,7
QA8AALS115BP48S08	80186604	70 – 115				200	2,79	452	50	25	1/2"	21,7
QA8AALS150BP48S08	80186612	75 – 150				145	3,12	489	50	25	1/2"	21,7
QA8AALS200BF56S12	80186620	100 – 200				110	4,02	508	53	30	3/4"	21,7
QA8AALS225BF56S12	80186638	125 – 225				90	4,02	508	53	30	3/4"	21,7

Atornilladores neumáticos

Angulares

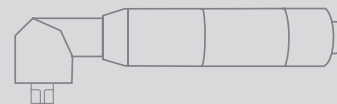







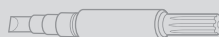











Adjustable cushion clutch



Adjustable shut-off clutch



Direct drive

Ref.	CCN	 Nm	 r. p. m.	 kg	 mm	 mm	 mm	 pulgadas	 l/s	
ARRANQUE POR PALANCA										
QA1L12D1LD	01385293	4	M4	1270	0,70	227	34	13	1/4" 	7,5
QA1L12D4LD	01379148	4	M4	1270	0,70	227	34	13	1/4" 	7,5
QA1L08D1LD	01385285	6,8	M5	850	0,70	227	34	13	1/4" 	7,5
QA1L08D4LD	01379155	6,8	M5	850	0,70	227	34	13	1/4" 	7,5
QA1L05D4LD	01380377	11,6	M6	500	0,70	227	34	13	1/4" 	7,5
5RLN2D6-EU	01340801	12,5	M6	600	1,40	276	33	13	3/8" 	8
7RLM2D6-EU	01340082	19,8	M8	800	1,40	286	33	13	3/8" 	12,7
7RLM3D6-EU	01340850	19,8	M6	800	1,60	295	38	18	3/8" 	12,7
7RLN3D6-EU	01338672	29,9	M8	500	1,60	295	38	18	3/8" 	12,7
9RSQ83-EU	01337864	111,5	M14	300	3,50	454	46	25	1/2" 	30,8

Especificaciones a 6,2 bares (90 psi)

Atornilladores neumáticos

En línea

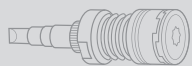





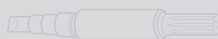

Adjustable cushion clutch



Adjustable shut-off clutch



Direct drive

Ref.	CCN	 Nm	 Nm	 Nm	 r. p. m.	 kg	 mm	 mm	 pulgadas	 l/s	
ARRANQUE POR PALANCA + EMPUJE											
QS1T20C1D	01385152	0,3 – 1,1	0,9 – 3,1		2000	0,70	241	22	1/4" Ⓞ	7,5	
QS1T05C1D	01385129	0,3 – 1,1	0,9 – 3,2	1,5 – 5,4	500	0,70	241	22	1/4" Ⓞ	7,5	
ARRANQUE POR PALANCA											
1RLNC1	04724530	0,3 – 1,8	0,5 – 2,6	1,1 – 3,4	M4	1000	0,50	222	14	1/4" Ⓞ	6,1
1RLMC1	04724548	0,5 – 1,8	0,7 – 2,3		M3	1650	0,50	222	14	1/4" Ⓞ	6,1
QS1L20C1D	01385053	0,3 – 1,1	0,9 – 3,1		2000	0,70	241	22	1/4" Ⓞ	7,5	
QS1L10C1D	01385038	0,3 – 1,1	0,9 – 2,5	1,5 – 4,5	1000	0,70	241	22	1/4" Ⓞ	7,5	
QS1L05C1D	01385020	0,3 – 1,1	0,9 – 3,2	1,5 – 5,4	500	0,70	241	22	1/4" Ⓞ	7,5	
41SC17LTQ4-EU	01341965IRI	1,1 – 4,5	1,7 – 6,8		1700	1,40	277	20	1/4" Ⓞ	9,4	
41SC10LTQ4-EU	01341122	1,1 – 4,5	1,7 – 9		1000	1,40	277	20	1/4" Ⓞ	9,4	
ARRANQUE POR EMPUJE											
1RPNC1	04724498	0,3 – 1,8	0,5 – 2,6	1,1 – 3,4	M4	1000	0,50	222	14	1/4" Ⓞ	6,1
1RPMC1	04724480	0,5 – 1,8	0,7 – 2,3		M3	1650	0,50	222	14	1/4" Ⓞ	6,1
QS1P20C1D	01385335	0,3 – 1,1	0,9 – 3,1		2000	0,62	223	22	1/4" Ⓞ	7,5	
41SC25PSQ4-EU	01339894	1,1 – 4,5			2500	1,30	264	20	1/4" Ⓞ	9,4	
QS1P10C1D	01385327	0,3 – 1,1	0,9 – 2,5	1,5 – 4,5	1000	0,62	223	22	1/4" Ⓞ	7,5	
QS1P05C1D	01385343	0,3 – 1,1	0,9 – 3,2	1,5 – 5,4	500	0,62	223	22	1/4" Ⓞ	7,5	
41SC10PSQ4-EU	01340868	1,1 – 4,5	1,7 – 9		1000	1,40	277	20	1/4" Ⓞ	9,4	

Especificaciones a 6,2 bares (90 psi)

Atornilladores neumáticos

En línea

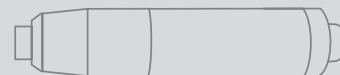



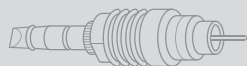



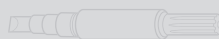









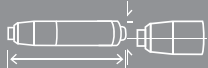



























Adjustable cushion clutch



Adjustable shut-off clutch



Direct drive

Ref.	CCN	 Nm	 Nm	 Nm	 Nm	 r. p. m.	 kg	 mm	 mm	 pulgadas	 l/s	
ARRANQUE POR PALANCA + EMPUJE												
QS1L20S1D	01373539		0,3 – 1,1	0,9 – 2,5		2000	0,70	241	22	1/4" 	7,5	
QS1L15S1D	45602497IRI		0,3 – 1,1	0,9 – 3,1		1500	0,70	241	22	1/4" 	7,5	
QS1L10S1D	01373513		0,3 – 1,1	0,9 – 2,5	1,5 – 4,5	1000	0,70	241	22	1/4" 	7,5	
QS1L02S1D	01389584		0,3 – 1,1	0,9 – 3,2	1,5 – 5,4	250	0,70	241	22	1/4" 	7,5	
QS1L05S1D	01373505		0,3 – 1,1	0,9 – 3,2	1,5 – 5,4	500	0,70	241	22	1/4" 	7,5	
41SA10LPQ4-EU	01342583IRI		1,7 – 4,5	2,8 – 6,8	4 – 9	1000	1,20	277	20	1/4" 	13,2	
41SA8LPQ4-EU	01341007		1,7 – 4,5	2,8 – 6,8	4 – 11,3	800	1,20	277	20	1/4" 	13,2	
ARRANQUE POR PALANCA												
1RLNS1	80094972		0,3 – 1,8	0,5 – 2,6	1,1 – 3,4	M4	1000	0,50	222	14	1/4" 	6,1
QS1T20S1D	01385251		0,3 – 1,1	0,9 – 2,5		2000	0,70	241	22	1/4" 	7,5	
QS1T15S1D	45602588IRI		0,3 – 1,1	0,9 – 3,1		1500	0,70	241	22	1/4" 	7,5	
1RLQS1	04725222		0,3 – 1,8	0,5 – 2,6	1 – 5,1	M5	500	0,50	222	17	1/4" 	6,1
LD1214RD5-Q4	04370169	1,1 – 2,5				1500	0,70	231	17	1/4" 	7,7	
LD1207RD5-Q4	04367421	1,2 – 4,2				800	0,70	231	17	1/4" 	7,7	
QS1T10S1D	01385236		0,3 – 1,1	0,9 – 2,5	1,5 – 4,5	1000	0,70	241	22	1/4" 	7,5	
QS1T02S1D	01389527IRI		0,3 – 1,1	0,9 – 3,2	1,5 – 5,4	250	0,70	241	22	1/4" 	7,5	
QS1T05S1D	01385228		0,3 – 1,1	0,9 – 3,2	1,5 – 5,4	500	0,70	241	22	1/4" 	7,5	
LD1202RD5-Q4	04367397	1,6 – 10				180	0,80	243	17	1/4" 	7,7	
LD2216RD5-Q4	04367546	1,8 – 4,5				1550	1	272	18	1/4" 	10,3	
LD2206RD5-Q4	04367488	2,1 – 9,8				600	1	272	18	1/4" 	10,3	
LD2210RD5-Q4	04370268	2,4 – 5,9				1000	1	272	18	1/4" 	10,3	
QA4ASLS012BP20S04		6 – 12				1050	1,30	351	21	1/4" 	13,7	
QA4ASRS012BF41S06	80188121	6 – 12				1050	1,30	451	21	3/8" 	13,7	
QA4ASLS015BP20S04		7 – 15				850	1,30	351	21	1/4" 	13,7	
QA4ASRS015BF41S06	47144555	7 – 15				850	1,30	451	21	3/8" 	13,7	
LD2203RD5-S6		10 – 15				300	1,10	293	18	3/8" 	10,3	
QA4ASLS020BP20S06	80166143	10 – 20				600	1,40	342	21	3/8" 	13,7	
QA4ASRS020BF41S06	80187917	10 – 20				600	1,40	451	21	3/8" 	13,7	
QA6ASLS025BP41S06	80186794	12 – 25				720	2,30	478	20	3/8" 	17	
QA6ASRS025BF41S06	80186919	12 – 25				700	2,61	454	34	3/8" 	17	
QA4ASLS027BP20S06	80166135	14 – 27				450	1,40	342	21	3/8" 	13,7	
QA4ASRS027BF41S06	47143565	14 – 27				450	1,40	451	21	3/8" 	13,7	
QA6ASLS030BP41S06	80186802	15 – 30				605	2,30	478	20	3/8" 	17	
QA6ASRS030BF41S06	80186927	15 – 30				585	2,61	454	34	3/8" 	17	
QA4ASLS046BP20S06	80166150	20 – 46				250	1,50	370	23	3/8" 	13,7	
QA4ASRS046BF41S06	17004284	20 – 46				250	1,50	465	23	3/8" 	13,7	

Atornilladores neumáticos

En línea



Adjustable cushion clutch



Adjustable shut-off clutch

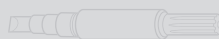

Direct drive

Ref.	CCN	Nm	Nm	Nm	Nm	r. p. m.	kg	mm	mm	pulgadas	l/s
QA6ASLS040BP41S06	80186810	20 – 40				450	2,30	478	20	3/8" □	17
QA6ASRS040BF41S06	80186935	20 – 40				435	2,61	454	34	3/8" □	17
QA8ASLS040BP41S06	80186836	20 – 40				600	2,39	502	20	3/8" □	21,7
QA8ASRS040BF41S06	17013434	20 – 40				540	2,73	478	34	3/8" □	21,7
QA6ASLS055BP41S08	80186828	25 – 55				325	2,31	478	20	1/2" □	17
QA6ASRS055BF41S08	80186943	25 – 55				315	2,62	454	34	1/2" □	17
QA8ASLS055BP41S08	80186851	25 – 55				470	2,40	502	20	1/2" □	21,7
QA8ASRS055BF41S08	80186976	25 – 55				425	2,74	478	34	1/2" □	21,7
QA8ASLS070BP41S08	80186869	35 – 70				355	2,54	506	24	1/2" □	21,7
QA8ASRS070BF41S08	80186984	35 – 70				320	3,09	482	43	1/2" □	21,7
QA8ASLS090BP41S08	80186877	45 – 90				255	2,87	542	24	1/2" □	21,7
QA8ASRS090BF41S08	80186992	45 – 90				230	3,42	518	43	1/2" □	21,7
QA8ASLS115BF41S08		70 – 115				215	3,40	541	51	1/2" □	21,7
QA8ASRS115BF41S08	80187008	70 – 115				195	3,64	517	51	1/2" □	21,7
QA8ASLS150BF41S08		75 – 150				165	3,40	541	51	1/2" □	21,7
QA8ASRS180BF41S08	17022583	90 – 180				125	3,64	517	51	1/2" □	21,7
ARRANQUE POR EMPUJE											
1RPN51	04724431	0,3 – 1,8	0,5 – 2,6	1,1 – 3,4	M4	1000	0,50	222	14	1/4" ⊙	6,1
1RPL51	80094907	0,5 – 1,5			M2	2800	0,50	213	14	1/4" ⊙	6,1
1RPM51	04724423	0,5 – 1,8	0,7 – 2,3		M3	1650	0,50	222	14	1/4" ⊙	6,1
QS1P20S1D	01375807	0,3 – 1,1	0,9 – 2,5			2000	0,62	223	22	1/4" ⊙	7,5
QS1P15S1D	45602554IRI	0,3 – 1,1	0,9 – 3,1			1500	0,62	223	22	1/4" ⊙	7,5
1RPQS1	04724449	0,3 – 1,8	0,5 – 2,6	1 – 5,1	M5	500	0,50	222	17	1/4" ⊙	6,1
LD1214RD3-Q4	04371175	1,1 – 2,5				1500	0,70	231	17	1/4" ⊙	7,7
LD1207RD3-Q4	04371167	1,2 – 4,2				800	0,70	231	17	1/4" ⊙	7,7
QS1P10S1D	01375781	0,3 – 1,1	0,9 – 2,5	1,5 – 4,5		1000	0,62	223	22	1/4" ⊙	7,5
QS1P02S1D	01386135	0,3 – 1,1	0,9 – 3,2	1,5 – 5,4		250	0,62	223	22	1/4" ⊙	7,5
QS1P05S1D	01375773	0,3 – 1,1	0,9 – 3,2	1,5 – 5,4		500	0,62	223	22	1/4" ⊙	7,5
LD1202RD3-Q4	53559415	1,6 – 10				180	0,80	243	17	1/4" ⊙	7,7
LD2216RD3-Q4	04380887	1,8 – 4,5				1550	1	272	18	1/4" ⊙	10,3
LD2206RD3-Q4	04381232	2,1 – 9,8				600	1	272	18	1/4" ⊙	10,3
LD2210RD3-Q4	53559423	2,4 – 5,9				1000	1	272	18	1/4" ⊙	10,3
41SA17PSQ4-EU	01340595	1,7 – 4,5	2,8 – 6,8			1700	1,20	277	20	1/4" ⊙	13,2
41SA10PSQ4-EU	01339100	1,7 – 4,5	2,8 – 6,8	4 – 9		1000	1,20	277	20	1/4" ⊙	13,2
41SA8PSQ4-EU	01339779	1,7 – 4,5	2,8 – 6,8	4 – 11,3		800	1,20	277	20	1/4" ⊙	13,2

Especificaciones a 6,2 bares (90 psi)

Atornilladores neumáticos

En línea

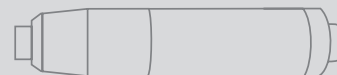







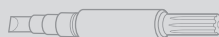

Adjustable cushion clutch



Adjustable shut-off clutch

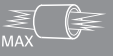

Direct drive

Ref.	CCN	 Nm	 r. p. m.	 kg	 mm	 mm	 pulgadas	 l/s	
ARRANQUE POR PALANCA									
QS1L20D1D	01385004	2,9	M3	2000	0,60	241	22	¼" 	7,5
QS1L10D1D	01384981	5,8	M5	1000	0,60	241	22	¼" 	7,5

Especificaciones a 6,2 bares (90 psi)

Herramientas de atornillado de precisión QA

Accesorios



GEM120-K48



GEA4-K48

Placa de montaje con brida		CCN	
ARRANQUE POR PALANCA			
QA4/QA8 – en línea	< 56 Nm	15EA-K48	
QA4/QA8 – angular	< 56 Nm		
QA6/QA8 – en línea	70/90 Nm	GEM120-K48	4642369
QA6/QA8 – angular	115/150 Nm		

Placa de montaje cuadrada		CCN	
ARRANQUE POR PALANCA			
QA6/QA8 – en línea	< 56 Nm	GEA4-K48	4696456
QA6/QA8 – angular	< 91 Nm		
QA6/QA8 – en línea	70/90 Nm	DAM120-K48	4340535
QA6/QA8 – angular	115/150 Nm		



GEA15-K48

Kit de barra de reacción		CCN	
ARRANQUE POR PALANCA			
QA6/QA8 – en línea	< 55 Nm	GEA15-K48	80132509
QA6/QA8 – angular	< 90 Nm		
QA6/QA8 – en línea	< 180 Nm	DEA120-K48*	4642369
QA6/QA8 – angular	< 150 Nm		

*Con un par máx. de 150 Nm y solo para modelos sin brida

Placa de montaje para serie AQ4 (para montaje vertical u horizontal)

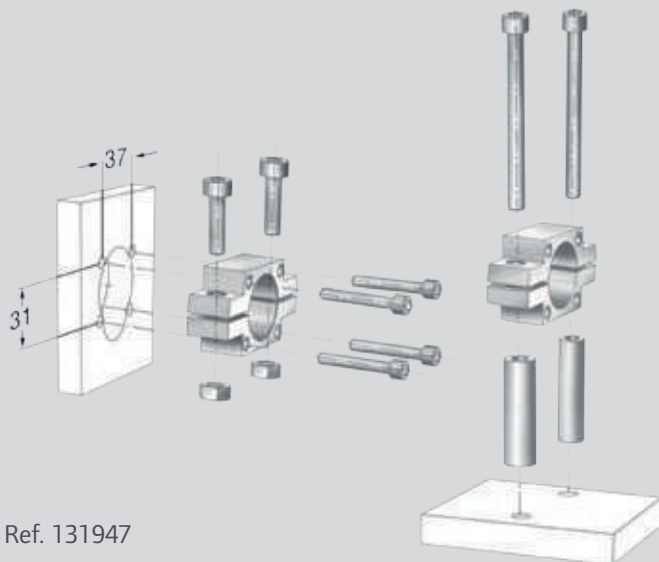

Ref. 131947



Ver nuestros brazos de reacción en la página 108

Llaves angulares

Accesorios



TRL-415-1
a TRL-415-5

Accesorios comunes para llaves angulares solamente

	Serie Q2	Serie 41	Serie 5	Serie 7	Serie 8	Serie 9
Husillo de cuadradillo de 1/4"	TRL2-A607-S4	48404-1	141A9-A607-1/4 (6,3 Nm máx.)	141A9-A607-1/4 (6,3 Nm máx.)	—	—
Husillo de cuadradillo de 3/8"	TRL2-A607-S6	48405-1	141A12-A607	141A12-A607	—	—
Husillo portapuntas hexagonal de 1/4"	TRL2-A607-Q4	48402-1	5L2C3-B586	5L2C3-B586	—	—
Husillo portapuntas de inserción de 1/4"	TRL2-A607-H4	48403-1	5L2C4-B386	5L2C4-B386	—	—
Extensión de cabezal angular de 150 mm	—	—	—	—	8SL-A327-6	8SL-A327-6
Cabezal angular con boca embutida* de 3/4"	—	—	—	—	—	182A88-807 (cabezal angular 83)
Cabezal angular con boca embutida* de 13 mm	—	—	—	8SA34-807M (cabezal angular 3D6)	8SA34-807M (cabezal angular 32) 182A13MF-807 (cabezal angular 53)	
Cabezal angular con boca embutida* de 15 mm	—	—	—	—	182A15MF-807 (cabezal angular 53)	
Cabezal angular con boca embutida* de 17 mm	—	—	—	—	8SA56-807M (cabezal angular 53)	
Cabezal angular con boca embutida* de 19 mm	—	—	—	—	—	182A88-807 (cabezal angular 83)
Piezas diferenciadas por el color: tapa para ajuste de carcasa del embrague	TRL-415-1 (oro) TRL-415-2 (rojo) TRL-415-3 (azul) TRL-415-4 (verde) TRL-415-5 (verde lima)	—	—	—	—	—

* Estas bocas sustituyen el cuadradillo estándar de la cabezal angular.



Fundas para cabezal angular

N.º de referencia	CCN	Descripción
131995	53454708	{QA4...011/ ...015/ ...020/ ...030}
131997	53454724	{QA4...040/ ...055} {QA6...030/ ...040/ ...055} {QA8...040/ ...055}
GEA40-172	80095409	{QA6...070/ ...090} {QA8...070/ ...090}
GEA40-173	80095789	{QA8...115/ ...150}
GEA240-173	45533766	{QA8...200/ ...225}



Herramientas de impulso neumáticas

Ingersoll Rand ofrece una completa línea de herramientas de impulso con parada automática y sin parada automática, y con configuración de pistola, angular y en línea, para adaptarse a sus requisitos concretos. Estas herramientas son extremadamente ligeras, y ofrecen potencia, velocidad, precisión y ergonomía excelentes.



Herramientas de impulso neumáticas



De pistola

Sin apagado automático	79
Con apagado automático	79

Herramientas de impulso neumáticas

Información de la serie

Serie Q

Representa la última generación de la tecnología de herramientas de impulso pensando en el usuario final.

- Margen de pares: 11 - 160 Nm
- Velocidad: 4000 - 7000 r. p. m.
- Motor sin lubricantes
- Diseño ergonómico que proporciona un agarre cómodo
- Atornillado de alta velocidad sin reacción
- Par constante
- Excelente rendimiento y durabilidad
- Las herramientas sin apagado automático están recomendadas para la mayoría de aplicaciones en las que priman la velocidad y la ergonomía



Serie QS

Representa la última generación de la tecnología de herramientas de impulso desarrolladas pensando en el usuario final.

- Margen de pares: 4,5 - 210 Nm
- Velocidad: 4300 - 6800 r. p. m.
- Motor sin lubricantes
- Diseño ergonómico que proporciona un agarre cómodo
- Atornillado de alta velocidad sin reacción
- Par constante
- Excelente rendimiento y durabilidad
- Apagado automático que limita el consumo de aire y el desgaste de la herramienta







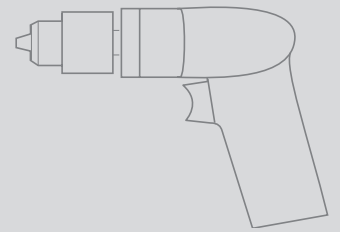











Herramientas de impulso neumáticas

De pistola





















Non-shut-off

Ref.	CCN	 Nm	 r. p. m.	 kg	 mm	 mm	 pulgadas	 l/s	
Q60PQ1	47136171	11 – 20	M6	4000	0,80	130	22	¼" 	5,2
Q60P3	47147681	13 – 22	M6	4000	0,80	130	22	⅜" 	5,2
Q70PQ1	80199326	20 – 28	M6	7000	0,80	131	21	¼" 	5,5
Q70P3	80199318	24 – 35	M6	7000	0,80	131	21	⅜" 	5,5
Q80PQ1	80199342	24 – 35	M8	7000	0,85	138	21	¼" 	5,8
Q80P3	80199334	33 – 50	M8	7000	0,85	138	21	⅜" 	5,8
Q90P3	80199359	47 – 65	M8	6500	0,97	148	23	⅜" 	6,7
Q110P4	80199367	65 – 100	M14	5500	1,40	164	26	½" 	9,7
Q120P4	45631405	95 – 130	M12	6600	1,70	175	29	½" 	13,7
Q140P4	45631512	130 – 160	M14	6000	2,20	190	33	½" 	15,6

Especificaciones a 6,2 bares (90 psi)

Shut-off

Ref.	CCN	 Nm	 r. p. m.	 kg	 mm	 mm	 pulgadas	 l/s	
QS50P3	48622120	4 – 8	M5	4300	0,95	164	23	⅜" 	4,2
QS50PQ1	48622112	4 – 8	M5	4300	0,95	164	23	¼" 	4,2
QS60PQ1	47135900	6 – 13	M6	5300	0,95	164	23	¼" 	5,7
QS60P3	47135892	7 – 15,5	M6	5300	0,95	164	23	⅜" 	5,7
QS70PQ1	47135926	13 – 28	M6	6800	1,10	177	23	¼" 	6,1
QS70P3	47135918	15 – 32	M6	6800	1,10	177	23	⅜" 	6,1
QS80P3	47135934	30 – 55	M8	6800	1,10	187	25	⅜" 	7,5
QS110P4	47149208	50 – 85	M10	5800	1,50	194	29	½" 	8,5
QS120P4	47149216	70 – 115	M12	5400	1,80	201	31	½" 	8,5
QS140P4	47149224	110 – 150	M14	5200	2,10	214	33	½" 	11,8
QS150P6	48622138	140 – 210	M16	4400	2,90	237	39	¾" 	11,8

Especificaciones a 6,2 bares (90 psi)



Aprietatuercas de precisión de CC

Las herramientas y los controladores QE se combinan para proporcionar precisión, ergonomía y durabilidad superiores así como cumplir los requisitos de apriete que usted tenga. Total control por transductor de bucle cerrado en un conjunto compacto y ligero para que su línea de producción pueda funcionar de forma más eficiente. Una completa línea de herramientas de primera categoría que, sea cual sea su sector (automoción, aeroespacial, electrónica, electrodomésticos o industria general), le ayudarán a maximizar su productividad.



Aprietatuercas de precisión de CC

	De pistola Transductor	31
	Angulares Transductor	32
	En línea Transductor	34

Aprietatuercas de precisión de CC

Información de la serie

Serie QE

Una combinación demostrada de primera categoría: juntos, las herramientas y los controladores QE proporcionan una precisión y durabilidad superiores, y cumplen todos sus requisitos de apriete. Los interruptores sin contacto, el tren de engranajes de servicio pesado y el motor de CC sin escobillas crean un conjunto duradero, mientras que su diseño ergonómico compacto y los controles fácilmente accesibles ayudan a los operarios a mantener la línea de producción en perfecto funcionamiento.

- Margen de pares: 0,3 - 320 Nm
- Velocidad: 500 - 3000 r. p. m.
- Control por transductor de bucle cerrado auténtico que proporciona una increíble precisión
- Estrategias de apriete y comunicaciones de procesos avanzadas
- Anillo de inversión de uso fácil
- Compacto, de alta velocidad y con controles de fácil acceso
- Alertas de mantenimiento preventivo
- LED brillantes que proporcionan indicaciones de estado visibles
- TactAlert que proporciona una respuesta positiva al operario sin distraerlo de su tarea
- Protección frente a sobrecalentamiento del motor
- Cómoda empuñadura y ergonómica



QE2PT002P10Q04



QE2AL003PA1S04









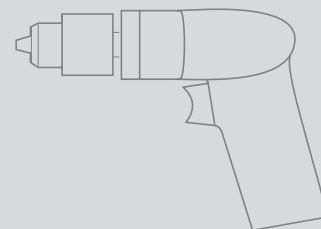



































QE2SP002P10Q04

Aprietatuercas de precisión de CC

De pistola



Transducer

Ref.	CCN	Nm	Nm MAX							
					r. p. m.	kg	mm	mm	pulgadas	V
CONTROL POR GATILLO										
QE2PT002P10Q04	46774634	0,3 – 1,6	2	M2	3000	0,66	250	19	1/4" 	Controlador IC 12
QE2PT002P10S04	46774642	0,3 – 1,6	2	M2	3000	0,66	242	19	1/4" 	Controlador IC 12
QE2PT003P10Q04	46774667	0,6 – 2,4	3	M2	2450	0,66	250	19	1/4" 	Controlador IC 12
QE2PT003P10S04	46774675	0,6 – 2,4	3	M2	2450	0,66	242	19	1/4" 	Controlador IC 12
QE2PT005P10Q04	46774691	1 – 4	5	M2	1700	0,66	250	19	1/4" 	Controlador IC 12
QE2PT005P10S04	46774709	1 – 4	5	M2	1700	0,66	242	19	1/4" 	Controlador IC 12
QE2PT007P10Q04	46774725	1,3 – 5,6	7	M2	1250	0,66	250	19	1/4" 	Controlador IC 12
QE2PT007P10S04	46774733	1,3 – 5,6	7	M2	1250	0,66	242	19	1/4" 	Controlador IC 12
QE2PT010P10Q04	46774758	2 – 8	10	M4	850	0,66	250	19	1/4" 	Controlador IC 12
QE2PT010P10S04	46774766	2 – 8	10	M4	850	0,66	242	19	1/4" 	Controlador IC 12
QE4PT010P10Q04	80175607	2 – 8	10	M4	1820	1,20	243		1/4" 	Controlador IC 12
QE4PT010P10S04	80175615IRI	2 – 8	10	M4	1820	1,20	230		1/4" 	Controlador IC 12
QE4PT015P10Q04	80175706IRI	3 – 12	15	M5	1220	1,20	243		1/4" 	Controlador IC 12
QE4PT015P10S04	80175714IRI	3 – 12	15	M5	1220	1,20	230		1/4" 	Controlador IC 12
QE4PT020P10S06	80175805IRI	4 – 16	20	M6	900	1,20	234		1/4" 	Controlador IC 12
QE4PT025P10S06	80175888IRI	5 – 20	25	M6	710	1,20	234		1/4" 	Controlador IC 12
ARRANQUE POR GATILLO + EMPUJE										
QE2PP002P11Q04	46774337	0,3 – 1,6	2	M2	3000	0,66	250	19	1/4" 	Controlador IC 12
QE2PP002P11S04	46774345	0,3 – 1,6	2	M2	3000	0,66	242	19	1/4" 	Controlador IC 12
QE2PP003P11Q04	46774360	0,6 – 2,4	3	M2	2450	0,66	250	19	1/4" 	Controlador IC 12
QE2PP003P11S04	46774378	0,6 – 2,4	3	M2	2450	0,66	242	19	1/4" 	Controlador IC 12
QE2PP005P11Q04	46774394	1 – 4	5	M2	1700	0,66	250	19	1/4" 	Controlador IC 12
QE2PP005P11S04	46774402	1 – 4	5	M2	1700	0,66	242	19	1/4" 	Controlador IC 12
QE2PP007P11Q04	46774428	1,3 – 5,6	7	M2	1250	0,66	250	19	1/4" 	Controlador IC 12
QE2PP007P11S04	46774436	1,3 – 5,6	7	M2	1250	0,66	242	19	1/4" 	Controlador IC 12
QE2PP010P11Q04	46774451	2 – 8	10	M4	850	0,66	250	19	1/4" 	Controlador IC 12
QE2PP010P11S04	46774469	2 – 8	10	M4	850	0,66	242	19	1/4" 	Controlador IC 12
ARRANQUE POR EMPUJE										
QE2PS002P11Q04	46774485	0,3 – 1,6	2	M2	3000	0,66	250	19	1/4" 	Controlador IC 12
QE2PS002P11S04	46774493	0,3 – 1,6	2	M2	3000	0,66	242	19	1/4" 	Controlador IC 12
QE2PS003P11Q04	46774519	0,6 – 2,4	3	M2	2450	0,66	250	19	1/4" 	Controlador IC 12
QE2PS003P11S04	46774527	0,6 – 2,4	3	M2	2450	0,66	242	19	1/4" 	Controlador IC 12
QE2PS005P11Q04	46774543	1 – 4	5	M2	1700	0,66	250	19	1/4" 	Controlador IC 12
QE2PS005P11S04	46774550	1 – 4	5	M2	1700	0,66	242	19	1/4" 	Controlador IC 12
QE2PS007P11Q04	46774576	1,3 – 5,6	7	M2	1250	0,66	250	19	1/4" 	Controlador IC 12
QE2PS007P11S04	46774584	1,3 – 5,6	7	M2	1250	0,66	242	19	1/4" 	Controlador IC 12
QE2PS010P11Q04	46774600	2 – 8	10	M4	850	0,66	250	19	1/4" 	Controlador IC 12
QE2PS010P11S04	46774618	2 – 8	10	M4	850	0,66	242	19	1/4"	Controlador IC 12

Aprietatuercas de precisión de CC Angulares

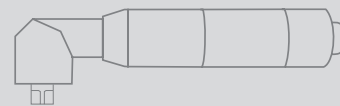

Transducer

Ref.	CCN										
		Nm	Nm MAX		r. p. m.	kg	mm	mm	mm	pulgadas	V
CONTROL MEDIANTE PALANCA											
QE2AL003PA1S04	46774006	0,8 – 3,2	4	M2	1750	0,83	312	27	9	¼" □	Controlador IC 12
QE2AL005PA3H04	46774196	1 – 4	5	M2	1590	0,95	318	34	13	¼" ○	Controlador IC 12
QE2AL005PA3Q04	46774204	1 – 4	5	M2	1590	0,95	318	34	13	¼" ⊙	Controlador IC 12
QE2AL005PA3S04	46774170	1 – 4	5	M2	1590	0,95	318	34	13	¼" □	Controlador IC 12
QE2AL005PA3S06	46774188	1 – 4	5	M2	1590	0,95	318	34	13	⅜" □	Controlador IC 12
QE2AL007PA3H04	46774238	1,4 – 5,6	7	M2	1100	0,95	318	34	13	¼" ○	Controlador IC 12
QE2AL007PA3Q04	46774246	1,4 – 5,6	7	M2	1100	0,95	318	34	13	¼" ⊙	Controlador IC 12
QE2AL007PA3S06	46774220	1,4 – 5,6	7	M2	1100	0,95	318	34	13	⅜" □	Controlador IC 12
QE2AL010PA3H04	46774279	2 – 8	10	M4	730	0,95	318	34	13	¼" ○	Controlador IC 12
QE2AL010PA3Q04	46774287	2 – 8	10	M4	730	0,95	318	34	13	¼" ⊙	Controlador IC 12
QE2AL010PA3S04	46774253	2 – 8	10	M4	730	0,95	318	34	13	¼" □	Controlador IC 12
QE2AL010PA3S06	46774261	2 – 8	10	M4	730	0,95	318	34	13	⅜" □	Controlador IC 12
QE2AL015PA3H04	46774311	3 – 12	15	M4	560	0,95	318	34	13	¼" ○	Controlador IC 12
QE2AL015PA3Q04	46774329	3 – 12	15	M4	560	0,95	318	34	13	¼" ⊙	Controlador IC 12
QE2AL015PA3S04	46774295	3 – 12	15	M4	560	0,95	318	34	13	¼" □	Controlador IC 12
QE2AL015PA3S06	46774303	3 – 12	15	M4	560	0,95	318	34	13	⅜" □	Controlador IC 12
QE4AT013PA2H04	16676876	3 – 10	13	M5	1200	1,30	383	32	13	¼" ○	Controlador IC 12
QE4AT013PA2Q04	16676884	3 – 10	13	M5	1200	1,30	383	32	13	¼" ⊙	Controlador IC 12
QE4AT013PA2S04	18427146	3 – 10	13	M5	1200	1,30	383	32	13	¼" □	Controlador IC 12
QE4AT013PA2S06	18427153	3 – 10	13	M5	1200	1,30	383	32	13	⅜" □	Controlador IC 12
QE4AT020PA2H04	16676918	4 – 16	20	M6	820	1,30	383	32	13	¼" ○	Controlador IC 12
QE4AT020PA2Q04	16676926	4 – 16	20	M6	820	1,30	383	32	13	¼" ⊙	Controlador IC 12
QE4AT020PA2S04	18427179	4 – 16	20	M6	820	1,30	383	32	13	¼" □	Controlador IC 12
QE4AT020PA2S06	16675464IRI	4 – 16	20	M6	820	1,30	383	32	13	⅜" □	Controlador IC 12
QE4AT027PA4S06	18427187	5 – 22	27	M8	600	1,30	387	42	17	⅜" □	Controlador IC 12
QE4AT027PA4S08	18427195	5 – 22	27	M8	600	1,30	387	42	17	½" □	Controlador IC 12
QE4AT034PA4S06	16675167	7 – 27	34	M8	470	1,30	387	42	17	⅜" □	Controlador IC 12
QE4AT034PA4S08	16676967	7 – 27	34	M8	470	1,30	387	42	17	½" □	Controlador IC 12
QE6AT030PA2S06	16674749	6 – 24	30	M8	1230	1,90	442	32	13	⅜" □	Controlador IC 12
QE6AT030PA4S08	18427351	6 – 24	30	M8	1230	1,90	447	42	17	½" □	Controlador IC 12
QE6AT040PA4S06	16675472	8 – 32	40	M8	910	1,90	447	42	17	⅜" □	Controlador IC 12
QE6AT040PA4S08	16675480	8 – 32	40	M8	910	1,90	447	42	17	½" □	Controlador IC 12
QE6AT055PA5S08	47130174	11 – 44	55	M10	650	1,90	453	45	22	½" □	Controlador IC 12

Aprietatuercas de precisión de CC Angulares

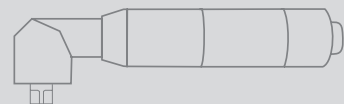

Transducer







































Ref.	CCN	Nm	Nm		r. p. m.	kg	mm	mm	mm	pulgadas	V
QE6AT080PA5S08	16674947	16 – 64	80	M10	440	1,90	453	45	22	½" □	Controlador IC 12
QE8AT065PA5S08	18427526	13 – 52	65	M10	1200	2,90	516	45	22	½" □	Controlador IC 12
QE8AT070PA5S08	18427534	14 – 56	70	M10	1100	2,90	516	45	22	½" □	Controlador IC 12
QE8AT090PA5S08	16675662	17 – 72	90	M10	850	2,90	516	45	22	½" □	Controlador IC 12
QE8AT115PA6S08	15969975	23 – 92	115	M12	660	2,90	520	50	24	½" □	Controlador IC 12
QE8AT150PA6S08	16675779	30 – 120	150	M12	510	2,90	520	50	24	½" □	Controlador IC 12
QE8AT225PA7S12	16679086	45 – 180	225	M16	310	4,10	575	55	28	¾" □	Controlador IC 12
QE8AT400FA8S12	16679094	80 – 320	400	M18	170	6	635	69	33	¾" □	Controlador IC 12

Aprietatuercas de precisión de CC

En línea



Transducer

Ref.	CCN	 Nm	 Nm		 r. p. m.	 kg	 mm	 mm	 mm	 mm	 pulgadas	 V
CONTROL MEDIANTE PALANCA												
QE2SL002F32S06	46774832	0,3 – 1,6	2	M2	3000	0,91	342	19	32	19		Controlador IC 12
QE2SL002P10Q04	46774881	0,3 – 1,6	2	M2	3000	0,60	250			22		Controlador IC 12
QE2SL002P10S04	46774899	0,3 – 1,6	2	M2	3000	0,60	242			22		Controlador IC 12
QE2SL003F32S06	46774840	0,6 – 2,4	3	M2	2450	0,91	342	19	32	19		Controlador IC 12
QE2SL003P10Q04	46774915	0,6 – 2,4	3	M2	2450	0,60	250			22		Controlador IC 12
QE2SL003P10S04	46774923	0,6 – 2,4	3	M2	2450	0,60	242			22		Controlador IC 12
QE2SL005F32S06	46774857	1 – 4	5	M2	1700	0,91	342	19	32	19		Controlador IC 12
QE2SL005P10Q04	46774949	1 – 4	5	M2	1700	0,60	250			22		Controlador IC 12
QE2SL005P10S04	46774956	1 – 4	5	M2	1700	0,60	242			22		Controlador IC 12
QE2SL007F32S06	46774865	1,3 – 5,6	7	M2	1250	0,91	342	19	32	19		Controlador IC 12
QE2SL007P10Q04	46774972	1,3 – 5,6	7	M2	1250	0,60	250			22		Controlador IC 12
QE2SL007P10S04	46774980	1,3 – 5,6	7	M2	1250	0,60	242			22		Controlador IC 12
QE2SL010F32S06	46774873	2 – 8	10	M4	850	0,91	342	19	32	19		Controlador IC 12
QE2SL010P10Q04	46775003	2 – 8	10	M4	850	0,60	250			22		Controlador IC 12
QE2SL010P10S04	46775011	2 – 8	10	M4	850	0,60	242			22		Controlador IC 12
QE4ST010B20S06		2 – 8	10	M4	1820	1,20	386		40	25		Controlador IC 12
QE4ST010B21S06	16985327	2 – 8	10	M4	1820	1,20	386	19	40	25		Controlador IC 12
QE4ST015B20S06	48389555	3 – 11	15	M5	1220	1,20	386		40	25		Controlador IC 12
QE4ST015B21S06	16985350	3 – 11	15	M5	1220	1,20	386	19	40	25		Controlador IC 12
QE4ST020B20S06	45501988	4 – 16	20	M6	900	1,20	386		40	25		Controlador IC 12
QE4ST020B21S06	16985384	4 – 16	20	M6	900	1,20	386	19	40	25		Controlador IC 12
QE4ST025B20S06	48394746	5 – 20	25	M6	710	1,20	386		40	25		Controlador IC 12
QE4ST025B21S06	16985418	5 – 20	25	M6	710	1,20	386	19	40	25		Controlador IC 12
QE6ST020F41S06	10564946IRI	4 – 16	20	M6	1840	2,10	501	19	113	27		Controlador IC 12
QE6ST020F61S06	10565638	4 – 16	20	M6	1840	2,10	544	38	144	27		Controlador IC 12
QE6ST028F41S06	16985434	6 – 22	28	M8	1360	2,10	501	19	113	27		Controlador IC 12
QE6ST028F61S06	10565786	6 – 22	28	M8	1360	2,10	544	38	144	27		Controlador IC 12
QE6ST033F41S06	16985442	7 – 26	33	M8	1130	2,10	501	19	113	27		Controlador IC 12
QE6ST033F61S06	10566321IRI	7 – 26	33	M8	1130	2,10	544	38	144	27		Controlador IC 12
QE6ST050F41S08	16985459	10 – 40	50	M10	760	2,10	501	19	113	27		Controlador IC 12
QE6ST050F61S08	10566826IRI	10 – 40	50	M10	760	2,10	544	38	144	27		Controlador IC 12
QE8ST055F41S08	10567956IRI	11 – 44	55	M10	1470	3	557	19	109	30		Controlador IC 12
QE8ST055F61S08	10568004IRI	11 – 44	55	M10	1470	3	608	38	141	30		Controlador IC 12
QE8ST070F41S08	16985475	14 – 56	70	M10	1160	3	557	19	109	30		Controlador IC 12
QE8ST070F61S08	10568178IRI	14 – 56	70	M10	1160	3	608	38	141	30		Controlador IC 12
QE8ST090F41S08	16675753	18 – 72	90	M10	900	3	557	19	109	30		Controlador IC 12

Aprietatuercas de precisión de CC

En línea



Transducer

Ref.	CCN	Nm	Nm		r. p. m.	kg	mm	mm	mm	mm	pulgadas	V
QE8ST090F61S08	10568277IRI	18 – 72	90	M10	900	3	608	38	141	30	½" □	Controlador IC 12
QE8ST150F41S08	16985483	30 – 120	150	M12	500	3,40	572	19	109	31	½" □	Controlador IC 12
QE8ST150F61S08	10568327IRI	30 – 120	150	M12	500	3,40	623	38	150	31	½" □	Controlador IC 12
QE8ST230F61S08	45497187	46 – 184	230	M18	340	5,50	710	38	150	36	½" □	Controlador IC 12
QE8ST230F62S12	18427674	46 – 184	230	M18	340	5,50	717	38	155	36	¾" □	Controlador IC 12
QE8ST230F82S12	45601366	46 – 184	230	M18	340	5,50	768	38	155	36	¾" □	Controlador IC 12
ARRANQUE POR PALANCA + EMPUJE												
QE2SP002P11Q04	46775037	0,3 – 1,6	2	M2	3000	0,60	250			22	¼" ⦿	Controlador IC 12
QE2SP002P11S04	46775045	0,3 – 1,6	2	M2	3000	0,60	242			22	¼" □	Controlador IC 12
QE2SP003P11Q04	46775060	0,6 – 2,4	3	M2	2450	0,60	250			22	¼" ⦿	Controlador IC 12
QE2SP003P11S04	46775078	0,6 – 2,4	3	M2	2450	0,60	242			22	¼" □	Controlador IC 12
QE2SP005P11Q04	46775094	1 – 4	5	M2	1700	0,60	250			22	¼" ⦿	Controlador IC 12
QE2SP005P11S04	46775102	1 – 4	5	M2	1700	0,60	242			22	¼" □	Controlador IC 12
QE2SP007P11Q04	46775128	1,3 – 5,6	7	M2	1250	0,60	250			22	¼" ⦿	Controlador IC 12
QE2SP007P11S04	46775136	1,3 – 5,6	7	M2	1250	0,60	242			22	¼" □	Controlador IC 12
QE2SP010P11Q04	46775151	2 – 8	10	M4	850	0,60	250			22	¼" ⦿	Controlador IC 12
QE2SP010P11S04	46775169	2 – 8	10	M4	850	0,60	242			22	¼" □	Controlador IC 12
ARRANQUE POR EMPUJE												
QE2TS002P11Q04	46775185	0,3 – 1,6	2	M2	3000	0,57	250			22	¼" ⦿	Controlador IC 12
QE2TS002P11S04	46775193	0,3 – 1,6	2	M2	3000	0,57	242			22	¼" □	Controlador IC 12
QE2TS003P11Q04	46775219	0,6 – 2,4	3	M2	2450	0,57	250			22	¼" ⦿	Controlador IC 12
QE2TS003P11S04	46775227	0,6 – 2,4	3	M2	2450	0,57	242			22	¼" □	Controlador IC 12
QE2TS005P11Q04	46775243	1 – 4	5	M2	1700	0,57	250			22	¼" ⦿	Controlador IC 12
QE2TS005P11S04	46775250	1 – 4	5	M2	1700	0,57	242			22	¼" □	Controlador IC 12
QE2TS007P11Q04	46775276	1,3 – 5,6	7	M2	1250	0,57	250			22	¼" ⦿	Controlador IC 12
QE2TS007P11S04	46775284	1,3 – 5,6	7	M2	1250	0,57	242			22	¼" □	Controlador IC 12
QE2TS010P11Q04	46775300	2 – 8	10	M4	850	0,57	250			22	¼" ⦿	Controlador IC 12
QE2TS010P11S04	46775318	2 – 8	10	M4	850	0,57	242			22	¼" □	Controlador IC 12
QE4TS010R11Q04	16678955	2 – 8	10	M4	1820	1,20	363			25	¼" ⦿	Controlador IC 12
QE4TS010R11S04	16678963	2 – 8	10	M4	1820	1,20	343			25	¼" □	Controlador IC 12
QE4TS010R11S06	16678971	2 – 8	10	M4	1820	1,20	343			25	⅜" □	Controlador IC 12
QE4TS015R11Q04	18427278	3 – 12	15	M5	1220	1,20	363			25	¼" ⦿	Controlador IC 12
QE4TS015R11S04	16678989	3 – 12	15	M5	1220	1,20	343			25	¼" □	Controlador IC 12
QE4TS015R11S06	16678997	3 – 12	15	M5	1220	1,20	343			25	⅜" □	Controlador IC 12
QE4TS020R11S06	16679003	4 – 16	20	M6	900	1,20	343			25	⅜" □	Controlador IC 12
QE4TS025R11S06	16679011	5 – 20	25	M6	710	1,20	343			25	⅜" □	Controlador IC 12



Llaves fijas de CC

Los motores de servicio pesado ofrecen gran precisión y control en aplicaciones con muy poca holgura. Usadas en configuraciones de un solo husillo o de varios, estas herramientas de primera categoría proporcionan un alto rendimiento y una larga vida útil. Las herramientas de la serie QM son el caballo de batalla para su aplicación de husillos múltiples. Con cuatro plataformas que proporcionan un amplio margen de pares y velocidades, los husillos QM de Ingersoll Rand proporcionan el nivel más alto de rendimiento, durabilidad y fiabilidad del sector.



Llaves fijas de CC

Llaves eléctricas fijas QE



Angulares

Transductor

39



En línea

Transductor

40

Husillos eléctricos QM

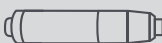

En línea

Transductor

42

Accesorios

44

Llaves fijas de CC

Información de la serie

Serie QE

Esta serie ofrece todas las ventajas de la serie QE estándar. El tren de engranajes de servicio pesado y el motor de CC sin escobillas crean un conjunto duradero que mantendrá la línea de producción en perfecto funcionamiento y reducirá los costes de mantenimiento. Los modelos con eje descentrado integral satisfacen los requisitos de poca holgura.

- Margen de pares: 0,3 - 320 Nm
- Velocidad: 170 - 3000 r.p.m.
- Control por transductor de bucle cerrado auténtico que proporciona una increíble precisión
- Estrategias de apriete y comunicaciones de procesos avanzadas
- Durabilidad excepcional gracias a la ausencia de interruptor en la herramienta, el tren de engranajes de servicio pesado y el motor de CC sin escobillas
- Alertas de mantenimiento preventivo
- LED brillantes que proporcionan indicaciones de estado visibles
- Llaves fijas eléctricas descentradas QE6Z y QE8Z



QE6AC040FA4S06



QE25SC002F32S06



QE6ZC020P52S06

Serie QM

Los motores de servicio pesado le ofrecen gran precisión y control sobre su aplicación de apriete. Usadas en configuraciones de un solo husillo o de varios, estas herramientas de primera categoría proporcionan un alto rendimiento y una larga vida útil.

- Margen de pares: 2 - 1900 Nm
- Velocidad: 25 - 1382 r. p. m.
- Capacidad superior al 5 %
- Los motores y componentes con ciclos de alto rendimiento son muy duraderos
- La cápsula electrónica externa simplifica la integración
- Hay modelos con o sin husillos, y con diversas longitudes y accionamientos









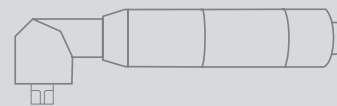



























QM3SS008H22S06

Llaves fijas de CC

Llaves eléctricas fijas QE | Angulares



Transducer









Ref.	CCN	 Nm	 MAX Nm		 r. p. m.	 kg	 mm	 mm	 mm	 pulgadas
QE4AC013BA2H04		3 – 10	13	M5	1200	1,30	383	32	13	1/4" 
QE4AC013BA2Q04		3 – 10	13	M5	1200	1,30	383	32	13	1/4" 
QE4AC013BA2S04	47125729	3 – 10	13	M5	1200	1,30	383	32	13	1/4" 
QE4AC013BA2S06		3 – 10	13	M5	1200	1,30	383	32	13	3/8" 
QE4AC020BA2H04		4 – 16	20	M6	820	1,30	383	32	13	1/4" 
QE4AC020BA2Q04		4 – 16	20	M6	820	1,30	383	32	13	1/4" 
QE4AC020BA2S04		4 – 16	20	M6	820	1,30	383	32	13	1/4" 
QE4AC020BA2S06	45669959	4 – 16	20	M6	820	1,30	383	32	13	3/8" 
QE4AC027BA4S06	80235666	5 – 22	27	M8	600	1,30	387	42	17	3/8" 
QE4AC027BA4S08		5 – 22	27	M8	600	1,30	387	42	17	1/2" 
QE6AC030FA2S06		6 – 24	30	M8	1230	1,90	442	32	13	3/8" 
QE6AC030FA4S08	47526343001	6 – 24	30	M8	1230	1,90	447	42	17	1/2" 
QE4AC034BA4S06	45645041	7 – 27	34	M8	470	1,30	387	42	17	3/8" 
QE4AC034BA4S08		7 – 27	34	M8	470	1,30	387	42	17	1/2" 
QE6AC040FA4S06		8 – 32	40	M8	910	1,90	447	42	17	3/8" 
QE6AC040FA4S08	47082037	8 – 32	40	M8	910	1,90	447	42	17	1/2" 
QE6AC055FA5S08	47096227	11 – 44	55	M10	650	1,90	453	45	22	1/2" 
QE8AC065FA5S08		13 – 52	65	M10	1200	2,90	516	45	22	1/2" 
QE8AC070FA5S08	18427450	14 – 56	70	M10	1100	2,90	516	45	22	1/2" 
QE6AC080FA5S08		16 – 64	80	M10	440	1,90	453	45	22	1/2" 
QE8AC090FA5S08	47096656	18 – 72	90	M10	850	2,90	516	45	22	1/2" 
QE8AC115FA6S08	80217300	23 – 92	115	M12	660	2,90	520	50	24	1/2" 
QE8AC150FA6S08	45634664	30 – 120	150	M12	510	2,90	520	50	24	1/2" 
QE8AC225FA7S12	80217292	45 – 180	225	M16	310	4,10	575	55	28	3/4" 
QE8AC400FA8S12	18427468	80 – 320	400	M18	170	6	635	69	33	3/4" 

Llaves fijas de CC

Llaves eléctricas fijas QE | En línea



Transducer









Ref.	CCN	 Nm	 MAX Nm		 r. p. m.	 kg	 mm	 mm	 mm	 pulgadas
QE2SC002F32S06	46774782	0,3 – 1,6	2	M2	3000	0,91	342	19	32	3/8" □
QE2SC003F32S06	46774790	0,6 – 2,4	3	M2	2450	0,91	342	19	32	3/8" □
QE2SC005F32S06	46774808IRI	1 – 4	5	M2	1700	0,91	342	19	32	3/8" □
QE2SC007F32S06	46774816	1,3 – 5,6	7	M2	1250	0,91	342	19	32	3/8" □
QE2SC010F32S06	46774824	2 – 8	10	M4	850	0,91	342	19	32	3/8" □
QE4SC010B20S06		2 – 8	10	M4	1820	1,20	386		40	3/8" □
QE4SC010B21S06	80239049	2 – 8	10	M4	1820	1,20	386	19	40	3/8" □
QE4SC010B41S06	16986721	2 – 8	10	M4	1820	1,20	437	19	74	3/8" □
QE4SC015B20S06		3 – 11	15	M5	1220	1,20	386		40	3/8" □
QE4SC015B21S06	45506961	3 – 11	15	M5	1220	1,20	386	19	40	3/8" □
QE4SC015B41S06	16986739	3 – 11	15	M5	1220	1,20	437	19	74	3/8" □
QE4SC020B20S06		4 – 16	20	M6	900	1,20	386		40	3/8" □
QE4SC020B21S06	45659398	4 – 16	20	M6	900	1,20	386	19	40	3/8" □
QE4SC020B41S06	16986747	4 – 16	20	M6	900	1,20	437	19	74	3/8" □
QE4SC025B20S06		5 – 20	25	M6	710	1,20	386		40	3/8" □
QE4SC025B21S06	47100953	5 – 20	25	M6	710	1,20	386	19	40	3/8" □
QE4SC025B41S06	16986754	5 – 20	25	M6	710	1,20	437	19	74	3/8" □
QE6SC020F41S06	18427369	4 – 16	20	M6	1840	2,10	501	19	113	3/8" □
QE6SC020F61S06	16986762	4 – 16	20	M6	1840	2,10	544	38	144	3/8" □
QE6SC020F81S06	18427377	4 – 16	20	M6	1840	2,10	594	38	195	3/8" □
QE6SC028F41S06	16993685	6 – 22	28	M8	1360	2,10	501	19	113	3/8" □
QE6SC028F61S06	16986770	6 – 22	28	M8	1360	2,10	544	38	144	3/8" □
QE6SC028F81S06		6 – 22	28	M8	1360	2,10	594	38	195	3/8" □
QE6SC033F41S06	18427385	7 – 26	33	M8	1130	2,10	501	19	113	3/8" □
QE6SC033F61S06	16986788	7 – 26	33	M8	1130	2,10	544	38	144	3/8" □
QE6SC033F81S06	48376503	7 – 26	33	M8	1130	2,10	594	38	195	3/8" □
QE6SC050F41S08	18427419	10 – 40	50	M10	760	2,10	501	19	113	1/2" □
QE6SC050F61S08	16986796	10 – 40	50	M10	760	2,10	544	38	144	1/2" □
QE6SC050F81S08		10 – 40	50	M10	760	2,10	594	38	195	1/2" □
QE6ZC020P42S06	10567030IRI	4 – 16	20	M6	1840	2,50	664	51	130	3/8" □
QE6ZC020P52S06	16986846IRI	4 – 16	20	M6	1840	2,50	647	51	130	3/8" □
QE6ZC028P52S06	16987315	5 – 20	28	M8	1360	2,50	647	51	130	3/8" □
QE6ZC033P52S06	10567436IRI	7 – 26	33	M8	1130	2,50	647	51	130	3/8" □
QE6ZC050P52S06	16678039	10 – 40	50	M10	760	2,50	647	51	130	3/8" □
QE8SC055F41S08	80240401	11 – 44	55	M10	1470	3	557	19	109	1/2" □
QE8SC055F61S08	16986804	11 – 44	55	M10	1470	3	608	38	140	1/2" □

Llaves fijas de CC

Llaves eléctricas fijas QE | En línea



Transducer









Ref.	CCN	 Nm	 Nm	 Nm	 r. p. m.	 kg	 mm	 mm	 mm	 pulgadas
QE8SC055F81S08	47087101	11 – 44	55	M10	1470	3	659	38	191	1/2" □
QE8SC070F41S08	18427575	14 – 56	70	M10	1160	3	557	19	109	1/2" □
QE8SC070F61S08	16986812	14 – 56	70	M10	1160	3	608	38	140	1/2" □
QE8SC070F81S08		14 – 56	70	M10	1160	3	659	38	191	1/2" □
QE8SC090F41S08	18427609	18 – 72	90	M10	900	3	557	19	109	1/2" □
QE8SC090F61S08	16985517	18 – 72	90	M10	900	3	608	38	140	1/2" □
QE8SC090F81S08	16985509	18 – 72	90	M10	900	3	659	38	191	1/2" □
QE8SC150F41S08	80165962	30 – 120	150	M12	500	3,40	572	19	109	1/2" □
QE8SC150F61S08	16986820	30 – 120	150	M12	500	3,40	623	38	140	1/2" □
QE8SC150F81S08	45634656	30 – 120	150	M12	500	3,40	674	38	191	1/2" □
QE8SC230F02S12		45 – 185	230		340	5,50	812	50	241	3/4" □
QE8SC230F22S12		45 – 185	230		340	5,50	853	50	291	3/4" □
QE8SC230F62S12	16989055	45 – 185	230		340	5,50	710	50	140	3/4" □
QE8SC230F82S12	16986838	45 – 185	230		340	5,50	761	50	191	3/4" □
QE8ZC055F52S06	10568376IRI	11 – 44	55	M10	1470	3	723	51	130	3/8" □
QE8ZC070F02S08		14 – 56	70	M10	1160	3	888	51	295	1/2" □
QE8ZC070F22S08		14 – 56	70	M10	1160	3	939	51	346	1/2" □
QE8ZC070F62S08	18427682	14 – 56	70	M10	1160	3	786	51	194	1/2" □
QE8ZC070F82S08		14 – 56	70	M10	1160	3	837	51	245	1/2" □
QE8ZC090F02S08		18 – 72	90	M10	900	4	888	51	295	1/2" □
QE8ZC090F22S08		18 – 72	90	M10	900	4	939	51	346	1/2" □
QE8ZC090F62S08	16985491	18 – 72	90	M10	900	4	786	51	194	1/2" □
QE8ZC090F82S08		18 – 72	90	M10	900	4	837	51	245	1/2" □
QE8ZC150F02S08		30 – 120	150	M12	500	4	888	51	295	1/2" □
QE8ZC150F22S08	42709741	30 – 120	150	M12	500	4	939	51	346	1/2" □
QE8ZC150F62S08	42712901	30 – 120	150	M12	500	4	786	51	194	1/2" □
QE8ZC150F82S08		30 – 120	150	M12	500	4	837	51	245	1/2" □

Llaves fijas de CC

Husillos eléctricos QM | En línea



Transducer

Ref.	CCN	 Nm	 Nm		 r. p. m.	 kg	 mm	 mm	 mm	 pulgadas
QM3SS008H22S06	18453217	2 – 6	8	M4	1382	2,70	599	50	300	3/8" □
QM3SS008H22S08	18453225	2 – 6	8	M4	1382	2,70	599	50	300	1/2" □
QM3SS008H62S06	18453175	2 – 6	8	M4	1382	2,40	449	50	150	3/8" □
QM3SS008H62S08	18453183	2 – 6	8	M4	1382	2,40	449	50	150	1/2" □
QM3SS008H92S06	18453191	2 – 6	8	M4	1382	2,40	524	50	225	3/8" □
QM3SS008H92S08	18453209	2 – 6	8	M4	1382	2,50	524	50	225	1/2" □
QM3SS012H22S06	18453266	3 – 10	12	M4	927	2,70	599	50	300	3/8" □
QM3SS012H22S08	18453274	3 – 10	12	M4	927	2,70	599	50	300	1/2" □
QM3SS012H62S06	18427690	3 – 10	12	M4	927	2,40	449	50	150	3/8" □
QM3SS012H62S08	18453233	3 – 10	12	M4	927	2,40	449	50	150	1/2" □
QM3SS012H92S06	18453241	3 – 10	12	M4	927	2,50	524	50	225	3/8" □
QM3SS012H92S08	18453258	3 – 10	12	M4	927	2,50	524	50	225	1/2" □
QM3SS016H22S06	18453324	4 – 13	16	M4	686	2,70	599	50	300	3/8" □
QM3SS016H22S08	18453332	4 – 13	16	M4	686	2,70	599	50	300	1/2" □
QM3SS016H62S06	18453282	4 – 13	16	M4	686	2,40	449	50	150	3/8" □
QM3SS016H62S08	18453290	4 – 13	16	M4	686	2,40	449	50	150	1/2" □
QM3SS016H92S06	18453308	4 – 13	16	M4	686	2,50	524	50	225	3/8" □
QM3SS016H92S08	18453316	4 – 13	16	M4	686	2,50	524	50	225	1/2" □
QM3SS020H22S06	18453373IRI	5 – 16	20	M5	545	2,70	599	50	300	3/8" □
QM3SS020H22S08	18453381	5 – 16	20	M5	545	2,70	599	50	300	1/2" □
QM3SS020H62S06	18427708	5 – 16	20	M5	545	2,40	449	50	150	3/8" □
QM3SS020H62S08	16992604	5 – 16	20	M5	545	2,40	449	50	150	1/2" □
QM3SS020H92S06	18453357	5 – 16	20	M5	545	2,50	524	50	225	3/8" □
QM3SS020H92S08	18453365	5 – 16	20	M5	545	2,40	524	50	225	1/2" □
QM5SS035H22S06	18453431	9 – 28	35	M6	590	4,20	673	50	300	3/8" □
QM5SS035H22S08	18453449	9 – 28	35	M6	590	4,20	673	50	300	1/2" □
QM5SS035H62S06	18453399IRI	9 – 28	35	M6	590	3,90	523	50	150	3/8" □
QM5SS035H62S08	18453407	9 – 28	35	M6	590	3,90	523	50	150	1/2" □
QM5SS035H92S06	18453415	9 – 28	35	M6	590	4	598	50	225	3/8" □
QM5SS035H92S08	18453423	9 – 28	35	M6	590	4	598	50	225	1/2" □
QM5SS055H22S06	18453480	14 – 44	55	M6	507	4,20	673	50	300	3/8" □
QM5SS055H22S08	18453498	14 – 44	55	M6	507	4,20	673	50	300	1/2" □
QM5SS055H62S06	16992612	14 – 44	55	M6	507	3,90	523	50	150	3/8" □
QM5SS055H62S08	18453456IRI	14 – 44	55	M6	507	3,90	523	50	150	1/2" □
QM5SS055H92S06	18453464	14 – 44	55	M6	507	4	598	50	225	3/8" □
QM5SS055H92S08	18453472	14 – 44	55	M6	507	4	598	50	225	1/2" □

Llaves fijas de CC

Husillos eléctricos QM | En línea



Transducer

Ref.	CCN									
		Nm	Nm		r. p. m.	kg	mm	mm	mm	pulgadas
QM55S090H22S08	18453514	23 – 72	90	M8	280	4,20	673	50	300	1/2" □
QM55S090H62S08	18427716	23 – 72	90	M8	280	3,90	523	50	150	1/2" □
QM55S090H92S08	18453506IRI	23 – 72	90	M8	280	4	598	50	225	1/2" □
QM75S190H22S08	18453548IRI	48 – 152	190	M10	273	8,90	794	50	300	1/2" □
QM75S190H22S12	18453555	48 – 152	190	M10	273	8,90	794	50	300	3/4" □
QM75S190H62S08	18453522	48 – 152	190	M10	273	8,40	645	50	150	1/2" □
QM75S190H62S12	18427724	48 – 152	190	M10	273	8,40	645	50	150	3/4" □
QM75S190H92S08	18453530	48 – 152	190	M10	273	8,60	720	50	225	1/2" □
QM75S190H92S12		48 – 152	190	M10	273	8,60	720	50	225	3/4" □
QM75S220H22S12	18453563	55 – 176	220	M10	233	8,90	794	50	300	3/4" □
QM75S220H62S12	18427732IRI	55 – 176	220	M10	233	8,40	645	50	150	3/4" □
QM75S220H92S12	80176076	55 – 176	220	M10	233	8,60	720	50	225	3/4" □
QM95S315H22S12	18453605	79 – 250	315	M10	278	19,50	860	50	300	3/4" □
QM95S315H22S16	18453613IRI	79 – 250	315	M10	278	19,60	860	50	300	1" □
QM95S315H62S12	18427740	79 – 250	315	M10	278	18,60	711	50	150	3/4" □
QM95S315H62S16	18453571	79 – 250	315	M10	278	18,70	711	50	150	1" □
QM95S315H92S12	18453589	79 – 250	315	M10	278	19,10	786	50	225	3/4" □
QM95S315H92S16	18453597	79 – 250	315	M10	278	19,20	786	50	225	1" □
QM95S435H22S12	18453662	109 – 346	435	M12	203	19,50	860	50	300	3/4" □
QM95S435H22S16	18453670	109 – 346	435	M12	203	19,60	860	50	300	1" □
QM95S435H62S12	18453621	109 – 346	435	M12	203	18,60	711	50	150	3/4" □
QM95S435H62S16	18453639	109 – 346	435	M12	203	18,70	711	50	150	1" □
QM95S435H92S12	18453647	109 – 346	435	M12	203	19,10	786	50	225	3/4" □
QM95S435H92S16	18453654	109 – 346	435	M12	203	19,20	786	50	225	1" □
QM95S520H22S12	18453720	130 – 410	520	M12	170	19,50	860	50	300	3/4" □
QM95S520H22S16	18453738	130 – 410	520	M12	170	19,60	860	50	300	1" □
QM95S520H62S12	18453688	130 – 410	520	M12	170	18,60	711	50	150	3/4" □
QM95S520H62S16	18453696	130 – 410	520	M12	170	18,70	711	50	150	1" □
QM95S520H92S12	18453704	130 – 410	520	M12	170	19,10	786	50	225	3/4" □
QM95S520H92S16	18453712	130 – 410	520	M12	170	19,20	786	50	225	1" □
QM95S650H62S16	18427757IRI	163 – 516	650	M14	136	18,70	711	50	150	1" □
QM95S650H92S16	18453746	163 – 516	650	M14	136	19,60	786	50	225	1" □
QM95S01KH62S16	80204761	250 – 800	1000	M16+	51	24,50	857	50	150	1" □
QM95S15CH62S24	80220718	250 – 1300	1500	M16+	51	32	869	50	150	1 1/2" □
QM95S18CH62S24	80220734	270 – 1500	1800	M16+	37	32	869	50	150	1 1/2" □
QM95S20CH62S24	80220759	300 – 1700	2000	M16+	31	32	869	50	150	1 1/2" □
QM95S22CH62S24	45487535	330 – 1900	2250	M16+	25	32	869	50	150	1 1/2" □

Llaves fijas de CC

Accesorios

Cable eléctrico (QE y QM)

Tipo de cable	Longitud	N.º de referencia	CCN
Cable estándar para herramientas	3 m	GEA40-CORD-3 M	22039887
	6 m	GEA40-CORD-6 M	80162043
	10 m	GEA40-CORD-10 M	80101959
Cable estándar de 90° (90° sobre herramienta lateral)	3 m	GEA40-CORD-3 M-90	80101496
	6 m	GEA40-CORD-6 M-90	80162050
	10 m	GEA40-CORD-10 M-90	80120785
Cable eléctrico flexible	3 m	CPS2-CORD-3 M	45553393
	6 m	CPS2-CORD-6 M	45612173
	10 m	CPS2-CORD-10 M	45612199
	15 m	CPS2-CORD-15 M	47106091
	50 m	CPS2-CORD-50 M	47106091
	6 m/90°	CCPS2-CORD-6 M-90	45612272
Cable de extensión	10 m	GEA40-EXT-10 M	80120702
	20 m	GEA40-EXT-20 M	80120793
	40 m	GEA40-EXT-40 M	80120801
Cable de extensión de 90° (lado del controlador)	1,5 m	GEA40-INT-02	80181423
	2 m	GEA40-INT-04	80181449
	2,5 m	GEA40-INT-06	80181464
	3 m	GEA40-INT-08	80181480



GEA40-CORD-3M-90

Motores QE2

Las herramientas se suministran sin el terminal de agarre delantero, de modo que los cabezales personalizados, incluidos los accesorios alimentadores de tornillo, se puedan acoplar de forma sencilla a la herramienta. Para pedir un motor QE2 utilice el mismo n.º de referencia que el de la herramienta estándar tipo pistola y en línea, pero sustituya las últimas dos cifras por "MO" (p. ej. QE2PS007PMO).



QE2PT010PMO



QE2SP005PMO

Llaves fijas de CC

Accesorios

Accesorios para atornilladores QE

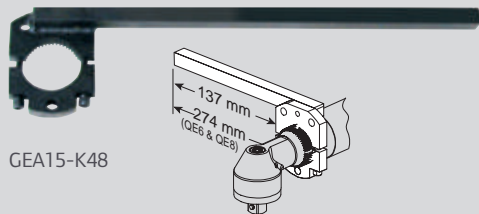

GEA15-K48



7L-365



GEA40-K98EL



GEA40-K364



GEM120-K48

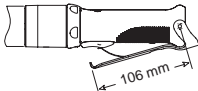
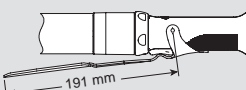

GEA4-K48

		N.º de referencia	CCN
Placa de montaje cuadrada ⁽¹⁾	Serie QE4	GEA4-K48	4696456
	QE6 y QE8	DAM120-K48	4340535
Placa de montaje con brida ⁽¹⁾	Serie QE4	15EA-K48	
	QE6 y QE8	GEM120-K48	80112790
Kit de palanca corta			
	QE4, QE6 y QE8	GEA40-M98SL	80096985
Kit de palanca extendida			
	QE4, QE6 y QE8	GEA40-K98EL	80146541
Kit de barra de reacción ⁽¹⁾	Serie QE4	GEA15-K48	80132509
	Serie QE4TS	GEPTS15-K48	16046021
	QE6 y QE8	DEA120-K48 ⁽²⁾	4642369
Suspensión giratoria	Serie QE2	CPS2-A365	45592979
	Serie QE4	GEA15-K364	45484722
Arco de suspensión	QE6 y QE8	GEA40-K364	4695565
	QE2, QE4	7L-365	3732922
	QE6, QE8		

(1) Necesita una tuerca de acoplamiento corta, ref. DAA4-27

(2) Con un par máx. de 150 Nm y solo para modelos sin brida



Fundas para cabezal angular

N.º de referencia	CCN	Descripción
131995	53454708	{QE2... todos los modelos} {QE4...013/ ...020}
131997	53454724	{QE4...027/ ...034} {QE6...030/ ...040} {QE6...055/ ...080}
GEA40-172	80095409	{QE8...065/ ...070/ ...090}
GEA40-173	80095789	{QE8...115/ ...150}
GEA240-173	45533766	{QE8...225}



Sistema de control – Herramientas de CC

Nuestros controladores son potentes y precisos, totalmente programables y pueden integrarse perfectamente en nuestras herramientas para aportar verdaderas ventajas de rendimiento. Incorporamos un control exhaustivo del par y el ángulo, así como capacidades de gestión de procesos, en un formato pequeño. Gracias a funciones estándar como las conexiones Ethernet y las de entrada / salida en cada unidad no hay gastos ocultos por maximizar la comunicación con su red.



Sistema de control – Herramientas de CC

48

Sistema de control – Herramientas de CC

Sistema de control del atornillado para herramientas eléctricas de las series QA y QM

Pantalla Insight IC12D

La pantalla profesional en color 1/4 VGA 216 resulta visible desde una distancia de 6,1 m.

El controlador cuenta con almacenamiento automático de 1000 ciclos de datos de fin de carrera.

La conexión Ethernet y la conexión de E/S, ambas estándar, optimizan las comunicaciones y la integración en la línea.

Suministro de energía de modo doble de 90 a 120 V de CA y de 200 a 240 V de CA

Ocho configuraciones básicas de apriete programables y acceso a un total de 256 almacenadas en la memoria.

Un margen de temperatura de funcionamiento de entre 0 y 50 °C garantiza un uso fiable en condiciones difíciles sin riesgo de sobrecalentamiento.

La tapa extraíble proporciona fácil acceso a conexiones y terminales.

Fácil instalación y configuración con práctico sistema de soportes.



La clave de transferencia de parámetros (PTK) permite cargar, recuperar, transferir y almacenar rápidamente conjuntos de configuración.

Módulo Insight IC1M

Almacenamiento automático de 200 ciclos de datos de fin de carrera.

La pantalla digital de una línea indica el par o el ángulo.

Mediante el programa ICS Connect se pueden programar las configuraciones y seleccionar cualquiera de las 256 básicas almacenadas en la memoria.



Sistema de control – Herramientas de CC

Sistema de control del atornillado para herramientas eléctricas de las series QA y QM

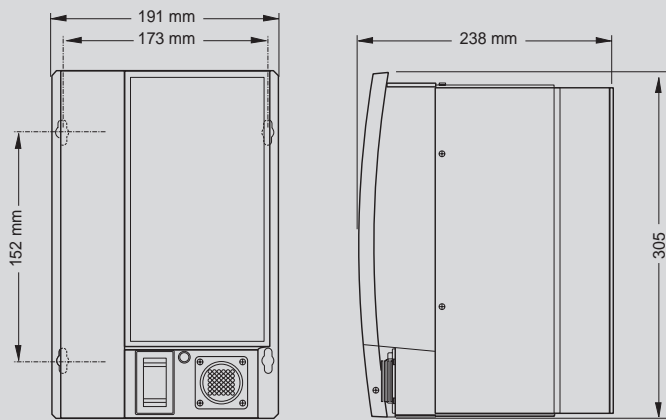

Pantalla Insight IC12 y módulo IC12

Modelos	Números de las herramientas o el husillo
Precisión de la medición	Par: $\pm 0,2$ % de par, escala completa ± 1 recuento angular (grados)
Resolución de la medición	$\pm 0,025$ % de par, escala completa
Excitación del puente del transductor de par	± 5 V de CC/Tierra
Compensación de deriva/ equilibrio del cero del transductor de par	$\pm 0,4$ % de escala completa
Sensibilidad de señal de entrada	2 mV/V
Calibración	Valores que se leen en la memoria del husillo Corrección digital automática
Respuesta de frecuencia (filtro de par)	A elegir entre 75 Hz, 150 Hz, 350 Hz, 500 Hz y 750 Hz
Teclado (solo IC-D)	Teclado de membrana con cuatro teclas programables, cuatro teclas de función, teclas numéricas y teclas de flechas
Pantalla	Pantalla plana iluminada 65K de 8 bits en color (QVGA), IC-D diagonal de 3,5 pulgadas, 320 x 240 píxeles o pantalla LED numérica IC-M de 5 caracteres y 7 segmentos
Conjuntos de parámetros	256
Número de ciclos almacenados en la memoria	IC-D: 1000. IC-M: 200
Memoria de datos estadísticos	100000 por husillo
Comunicaciones	Serie RS232, Ethernet, USB, Profibus opcional o DeviceNet
E/S	8 entradas/8 salidas, con comportamiento asignable mediante el software ICS, y 16 entradas y salidas adicionales con una tarjeta E/S opcional
Indicadores	Luz de encendido
Dispositivos adicionales	Tarjeta DeviceNet, tarjeta Profibus, E/S adicional, soporte de montaje en armario
Tensión de entrada	Monofásica de 120 voltios, 50/60 Hz y 16 A Monofásica de 230 voltios, 50/60 Hz y 8 A
Condiciones ambientales de funcionamiento	0 – 50 °C, 20/90 % de humedad sin condensación
Carcasa	IP-52
Peso del sistema	5,6 kg

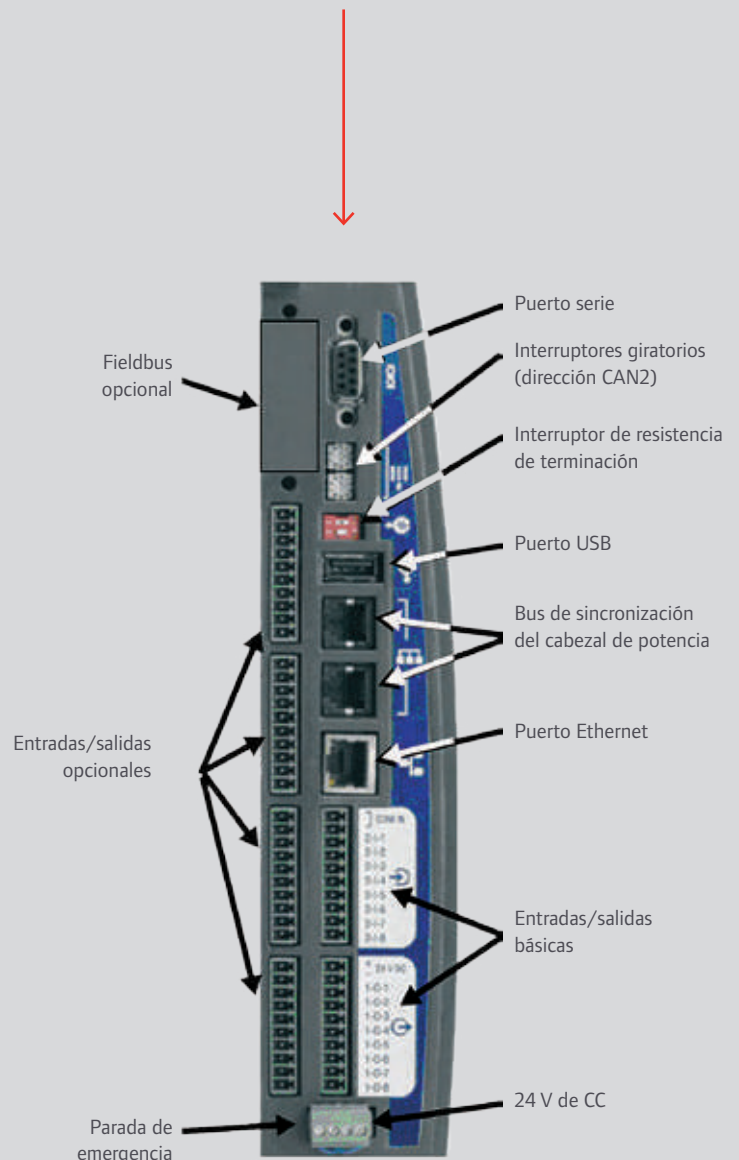

Sistema de control – Herramientas de CC

Sistema de control del atornillado para herramientas eléctricas de las series QA y QM

Pantalla Insight IC12 y módulo IC12

Códigos de identificación del modelo

Ejemplo: **IC12D3A1AWS**



Pantalla Insight IC12D



Módulo Insight IC12M

Definición del producto Insight

Modelos	Números de las herramientas o el husillo	Interfaz	Fuente de alimentación
IC Controlador INSIGHT	12 una herramienta/husillo	D M MÓDULO, sin interfaz de usuario PANTALLA, con interfaz de usuario	1 2 3 230 V CA, cable espiral, estándar europeo 220 V, cable espiral EE. UU. 115 V CA, enchufe, EE. UU.

Equipamiento opcional

E/S (entradas y salidas opcionales)	Paquete de comunicaciones	Clave de transferencia de parámetros	Tipo de montaje	Paquete de software
A B Una tarjeta de E/S adicional para un solo husillo Tarjeta de interfaz estándar de E/S	1 3 4 5 6 7 Opción 1 + Profinet Opción 1 + EtherNet/IP, Modbus-TCP Opción 1 + Interbus-S Opción 1 + Devicenet Opción 1 + Profibus Serie y Ethernet	A B Clave de transferencia de parámetros incluida Estándar (sin clave)	W C Montaje en armario Montaje estándar en pared	S XX Software personalizado Estándar

Sistema de control – Herramientas de CC

Sistema de control del atornillado para herramientas eléctricas de las series QA y QM

Accesorios para pantalla Insight IC12 y módulo Insight IC12



Interruptor de selección remota
4 posiciones - IC-SELECT-4
8 posiciones - IC-SELECT-8



Botón de parada de emergencia
IC-ESTOP



Estación de rearme
IC-PALM-RESET



Torre de señales, tipo LCE-FB
IC-LIGHT-TOWER



Bandeja de bocas
8 posiciones – IC-SOCKET-8



Bandeja de bocas
4 posiciones – IC-SOCKET-4



Clave de transferencia de parámetros
PC 80150113

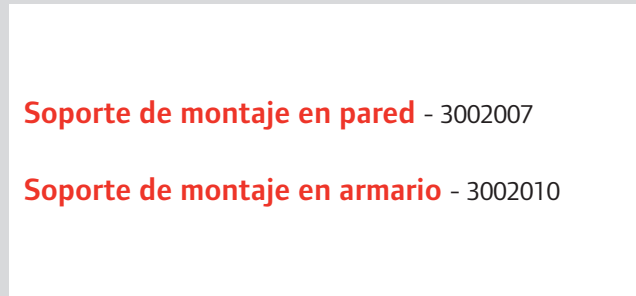

Soporte de montaje en pared - 3002007

Soporte de montaje en armario - 3002010



Cables de bandeja de selección de puntas

IC-19PIN-5M
CCN 45491073
IC-19PIN-10M
CCN 45473048

Cables de bandeja de selección de bocas

IC-10PIN-6M
CCN 45473048

Sistema de control – Herramientas de CC

Sistema de control del atornillado para herramientas eléctricas de las series QA y QM



En conjunción con un controlador IC12D o IC12M y un PC, nuestro revolucionario paquete de software ICS hace posible controlar y supervisar con mayor precisión su proceso de apriete.

ICS Connect

ICS Connect permite a los operarios acceder a, y programar, estrategias básicas de atornillado, así como ver los datos de ciclo con un solo controlador IC12D o IC12M a través de una conexión de Ethernet unívoca. ICS Connect viene de serie con todos los controladores IC12D y IC12M.



Requisitos del sistema:
PC con Windows 2000 o XP, conexión RJ45 y pantalla de 1024 x 768 o superior

ICS Network

ICS Network permite programar varios controladores IC12D y IC12M conectados mediante una red de área local (LAN) o mediante conexión directa. Esta opción también permite a los operarios programar estrategias de atornillado avanzadas, incluido el control de la elasticidad y del par predominante.



Sistema de control – Herramientas de CC

Sistema de control del atornillado para herramientas eléctricas de las series QA y QM



ICS MultiSync

El paquete ICS MultiSync facilita la configuración y el control de sistemas de husillos múltiples, que constan de hasta 100 husillos en grupos de hasta 40 husillos. Este paquete también ofrece estrategias avanzadas de atornillado con múltiples husillos, supervisión remota y almacenamiento de datos.

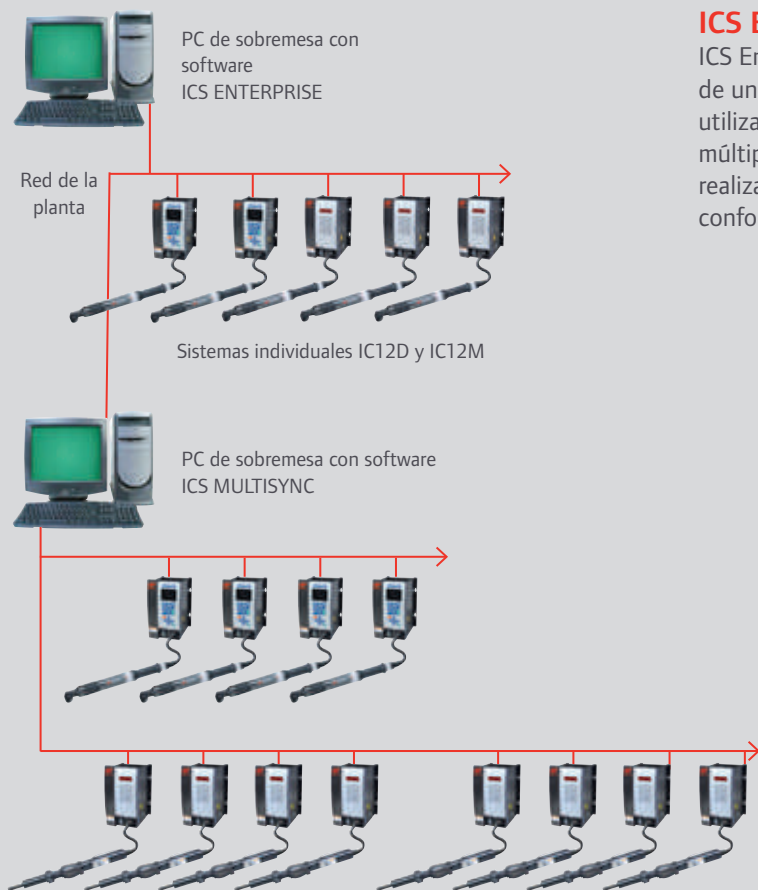

ICS Enterprise

ICS Enterprise ofrece programación y gestión avanzadas de una red de hasta 500 controladores IC12D o IC12M utilizados con herramientas QE, husillos QM o sistemas de múltiples husillos. También permite archivar información, realizar búsquedas y procesar estadísticas en bases de datos conforme a ODBC.

Matriz de funciones del software Insight

	Insight IC12M	Insight IC12D	Mediante ICS Connect	Mediante ICS Network	Mediante ICS MultiSync	Mediante ICS Enterprise
PROGRAMACIÓN DE SOFTWARE						
N.º máx. de configuraciones	256	256	Sin límite	Sin límite	Sin límite	Sin límite
N.º máx. de fases	32 por config.	32 por config.	1	32 por config.	32 por config.	32 por config.
Parám. de prog. editables		•	•	•	•	•
Recuento de ajuste de grupo		•	•	•	•	•
Autoincremento		•	•	•	•	•
Config. rápida		•	•	•	•	•
Config. avanzada			•	•	•	•
Nombre de config.		Solo visualización	•	•	•	•
Apriete en sent. horario/antihorario		•	•	•	•	•
Funcionamiento de la tuerca de tubo		•	•	•	•	•
Aceleración ajustable				•	•	•
EOR opcional para cada fase				•	•	•
Sincronización de husillos				•	•	•
Protección frente a copia			•	•	•	•
ARCHIVADO DE DATOS						
N.º de registros EOR almacenados	200	1000	Sin límite (manual)	Sin límite (manual)	Sin límite (auto.) ODBC	Sin límite (auto.) ODBC
Bases de datos transferibles a					•	•
Copia de datos de seguridad en el servidor					•	•
CABEZAL DE POTENCIA						
Funcionamiento del cabezal de potencia					•	•
N.º máx. de husillos en el cabezal de potencia					40	40
N.º máx. de grupos					8	8
Retroceso en caso de avería					•	•
Opciones de retroceso en caso de avería					Ninguna, husillo, grupo, cabezal de potencia	•
Retroceso final en caso de avería					•	•
Opciones de retroceso final en caso de avería					Ninguna, husillo, grupo, cabezal de potencia	•
Método de sincronización					Mediante CANBUS	
GENERALIDADES DEL SOFTWARE						
Ajuste de fecha/hora		•	•	•	•	•
Nombre de sistema		•	•	•	•	•
Mostrar versiones de software		•	•	•	•	•
Selección de idioma		•	Solo idioma ICS	Solo idioma ICS	Solo idioma ICS	Solo idioma ICS
Función NTP		•	•	•	•	•
Filtro de EOR en pantalla		•	•	•	•	•
EOR visible en pantalla	Solo valor primario	•	•	•	•	•
Cargar nuevo software por Ethernet	•	•	•	•	•	•
PROGRAMACIÓN DE HERRAMIENTAS						
Ajuste del margen del transductor (TR)		•	•	•	•	•
Ajuste de la escala de ángulo constante (ASC)		•	•	•	•	•
Restablecimiento de los parámetros TR y ASC		•	•	•	•	•
Función de calibración automática			X con ETA	X con ETA, solo conexión directa		
Selección de unidades de par		•	•	•	•	•
Selección de modo de arranque		•	•	•	•	•
Selección de funcionamiento de herramienta		•	•	•	•	•
Programación de interruptor Fn especial		•	•	•	•	•
Selección de modo de configuración		•	•	•	•	•
Alarmas de mantenimiento preventivo (PM)			•	•	•	•
Ver datos del chip de memoria			•	•	•	•
CONTRASEÑAS						
Número de contraseñas	0	1	Sin límite	Sin límite	Sin límite	Sin límite
Autobloqueo con temporizador			•			
Bloqueo ajustable con temporizador			•			
ESTADÍSTICA						
Estadística de muestras y poblacional			•	•	•	•
Valores estadísticos, calculados		Cp, Cpk, promedio, SD, capacidad, CAM, valor máx., valor mín., % n.º rechazos, % n.º aprobados, n.º rechazos alto, n.º rechazos bajo, desplazamiento medio, margen, n.º para sigma		Cp, Cpk, promedio, SD, capacidad, CAM, valor máx., valor mín., % n.º rechazos, % n.º aprobados, n.º rechazos alto, n.º rechazos bajo, desplazamiento medio, margen, n.º para sigma, objetivo		
Alarmas estadísticas				•	•	•
Salida de alarmas estadísticas	•	•				
Tamaño máx. de muestra estadística	200	1000	1000	1000	1000	1000
Estadística de cabezal de potencia		•		•	•	•
Gráficos de promedios				•	•	•
Histogramas				•	•	•
Diagrama de Pareto				•	•	•
Alarmas de estadísticas por correo electrónico					•	•
Las estadísticas se pueden calcular a partir de datos definidos por el usuario.				•	•	•
CURVAS DE APRIETE						
Tipos de curva			Par / ángulo, par / tiempo, corriente / tiempo y corriente / ángulo			
Máx. n.º de curvas almacenadas en cont.	Último rechazo Último ciclo	Último rechazo Último ciclo				
Mostrar curvas en pantalla				•	•	•

	Insight IC12M	Insight IC12D	Mediante ICS Connect	Mediante ICS Network	Mediante ICS MultiSync	Mediante ICS Enterprise
CURVAS DE APRIETE						
Imprimir curvas de apriete				•	•	•
Imprimir datos de curvas de apriete				•	•	•
Vista completa				•	•	•
Función zoom				•	•	•
N.º de curvas que pueden superponerse				1	10	10
Archivar curvas				•	•	•
Valores de parámetros mostrados en la curva				•	•	•
ESTRATEGIAS DE APRIETE						
Control de par		•	•	•	•	•
Control de par con anulac. de elast.				•	•	•
Control de ángulo		•	•	•	•	•
Control de ángulo con anulac. de elast.				•	•	•
Control de elasticidad				•	•	•
Par predominante				•	•	•
Par de arrastre				•	•	•
Retroceso				•	•	•
Retroceso en caso de avería					•	•
Retroceso final en caso de avería					•	•
Reajuste del par				•	•	•
Espera				•	•	•
Avance por impulsos				•	•	•
Derivación					•	•
COMUNICACIONES						
Puerto serie de salida de datos de EOR		•	•	•	•	•
Puerto serie personalizado de salida de datos EOR			•	•	•	•
Salida de datos del host		•	•	•	•	•
PFCs						
Código de barras pasivo				•	•	•
Código de barras activo				•	•	•
Configuración de código de barras en pantalla				•	•	•
Configuración de Fieldbus en pantalla				•	•	•
Programación de Ethernet			•	•	•	•
DIAGNÓSTICO						
Códigos de error	•					
Errores de texto		•	•	•	•	•
Prueba del sistema		•	•	•	•	•
Guardar resultados de prueba del sistema			•	•	•	•
Ver estado de entradas		•	•	•	•	•
Ajustar estado de salidas		•	•	Solo con conexión 1 a 1	•	
Ver salidas			•	•	•	•
Entradas asignables			•	•	•	•
Salidas asignables			•	•	•	•
Registro de eventos			•	•	•	•
Ver registro de eventos			•	•	•	•
Prueba de herramientas	•		•	Solo con conexión 1 a 1	•	
Prueba de luz	•		•	Solo con conexión 1 a 1	•	
AYUDA						
Menú de ayuda en pantalla			•	•	•	•
Texto de asistente		•				
INFORMES IMPRESOS						
N.º de informes	0	0	5	6	9	11
Tipos de informe			Registro de ciclos, estadística, volcado de parámetros, diagnóstico, registro de eventos			
				+Apriete, curva	+Apriete, histograma de curva, Pareto, promedio/margen	+Apriete, histograma de curva, Pareto, promedio/margen, VIN, personaliz.
Salida en paralelo			•	•	•	•
Exportar a archivo			•	•	•	•
HARDWARE						
Tamaño pantalla	14 mm de alto x 5 caracteres	9,6 cm (9/16 pulg.) diag.				
Tipo de pantalla	LED rojo	LCD en color VGA de 1/4	XVGA o superior	XVGA o superior	XVGA o superior	XVGA o superior
Teclado			•	•	•	•
Tipo de teclado		De membrana de 25 teclas	Teclado de PC	Teclado de PC	Teclado de PC	Teclado de PC
Luces de estado		En pantalla				
Indicador de encendido	•	•				
Disyuntor de fuga a tierra	•	•				
Diseño de montaje		Placa de montaje en pared o armario				
Fieldbus	X (opcional)	X (opcional)				
N.º de E/S	Básicas: 8, máx.: 24	Básicas: 8, máx.: 24				
Tipo de E/S	Opto	Opto				
Puerto serie	X (1)	X (1)				
Ethernet	•	•				
N.º máx. de husillos	1	1	1	500	100	500
Método de identificación de la ubicación física	Interruptor giratorio	Interruptor giratorio				
Interruptor de cortacircuitos	•	•				
PESO						
Peso	5,6 kg (12,4 lb)	5,6 kg (12,4 lb)				



Atornilladores eléctricos de par bajo

Usted tiene un trabajo crucial que hacer, y mucha gente confía en que lo hará bien. En Ingersoll Rand también sabemos qué es lo que está en juego. Por eso le ofrecemos los sistemas de atornillado eléctricos de CC con control de par y ángulo más innovadores y fiables del sector.



Atornilladores eléctricos de par bajo

	De pistola Con apagado automático	21
	Angulares Con apagado automático	22
	En línea Embrague ajustable con parada automática	23
	Controladores	24
	Accesorios	26

Atornilladores eléctricos de par bajo

Información de la serie

Serie VersaTec

Atornilladores de par bajo en un conjunto ergonómico de tamaño compacto

- Margen de pares: 0,03 - 6,4 Nm
- Velocidad: 260 - 2500 r. p. m.
- Conjunto ergonómico con empuñadura moldeada de tacto suave, accionamiento con dos dedos mediante palanca y un sencillo mando de inversión de giro que ofrecen al operario confort y productividad
- Velocidad variable y función de arranque suave integrados en el controlador
- Diseño ligero y compacto
- Control de par de ajustable externo
- Recomendado para aplicaciones de par bajo y control preciso del par y la velocidad
- Existen modelos con protección frente a descargas electrostáticas (con números de referencia terminados en "-ESD").



ET4004E



EL4011S2S5









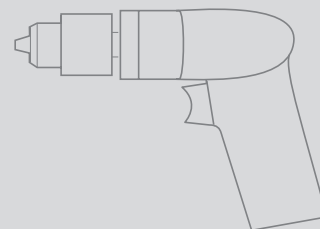





EL0410E

Atornilladores eléctricos de par bajo

De pistola



Adjustable shut-off clutch







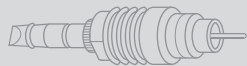
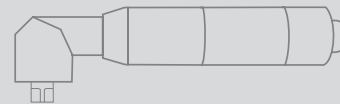







Ref.	CCN	 Nm	 r. p. m.	 kg	 mm	 mm	 pulgadas	 V
ARRANQUE POR PALANCA								
ET4004E	01348002	2 – 4,5	400	0,73	273	286	¼" 	CA 230
ET4005S	01359868	2 – 4,5	500	0,78	273	286	¼" 	CC 34
ET4011S	01352491	2 – 4,5	1100	0,78	273	286	¼" 	CC 34
ARRANQUE POR EMPUJE								
EP4004E	01348010	2 – 4,5	400	0,73	273	286	¼" 	CA 230
EP4005S	01359843	2 – 4,5	500	0,78	273	286	¼" 	CC 34
EP4011S	01359538	2 – 4,5	1100	0,78	273	286	¼" 	CC 34

Atornilladores eléctricos de par bajo

Angulares



Adjustable shut-off clutch







Ref.	CCN	 Nm	 1 min r. p. m.	 kg	 mm	 mm	 pulgadas	 V
ARRANQUE POR PALANCA								
EL1510E2S3	01347889	0,7 – 2,6	650	1	448	13	¼" 	CA 230
EL1510E2S5	01347822	0,7 – 2,6	650	1	448	13	¼" 	CA 230
EL1525S2S3	01359884	0,7 – 2,6	1600	0,95	448	13	¼" 	CC 34
EL1525S2S5	01359876	0,7 – 2,6	1600	0,95	448	13	¼" 	CC 34
EL4004E2S3	01347913	1,7 – 6,4	260	1	448	13	¼" 	CA 230
EL4004E2S5	01347855	1,7 – 6,4	260	1	448	13	¼" 	CA 230
EL4011S2S3	01359918	1,7 – 6,4	700	0,95	448	13	¼" 	CC 34
EL4011S2S5	01359900	1,7 – 6,4	700	0,95	448	13	¼" 	CC 34

Atornilladores eléctricos de par bajo

En línea



Adjustable shut-off clutch

Ref.	CCN	 Nm	 r. p. m.	 kg	 mm	 mm	 pulgadas	 V
ARRANQUE POR PALANCA								
EL0109E	01347731	0 – 0,2	950	0,32		235	4 mm Ø	CC 24
EL0410E	01347749	0,1 – 0,5	1000	0,36		235	¼" Ⓞ	CC 24
EL1007E	01347764	0,6 – 1,2	700	0,36		235	¼" Ⓞ	CC 24
EL1510E	01347962	0,6 – 1,7	1000	0,73	273	286	¼" Ⓞ	CA 230
EL1512S	01352467	0,6 – 1,7	1200	0,68	273	286	¼" Ⓞ	CC 34
EL1525S	01352475	0,6 – 1,7	2500	0,68	273	286	¼" Ⓞ	CC 34
EL2607E	01347988	1,2 – 2,9	700	0,73	273	286	¼" Ⓞ	CA 230
EL2608S	01359850	1,2 – 2,9	800	0,68	273	286	¼" Ⓞ	CC 34
EL2616S	01352483	1,2 – 2,9	1600	0,68	273	286	¼" Ⓞ	CC 34
ARRANQUE POR EMPUJE								
EP1510E	01347970	0,6 – 1,7	1000	0,73	273	286	¼" Ⓞ	CA 230
EP1512S	01352509	0,6 – 1,7	1200	0,68	273	286	¼" Ⓞ	CC 34
EP1525S	01352517	0,6 – 1,7	2500	0,68	273	286	¼" Ⓞ	CC 34
EP2607E	01347996	1,2 – 2,9	700	0,73	273	286	¼" Ⓞ	CA 230
EP2608S	01359835	1,2 – 2,9	800	0,68	273	286	¼" Ⓞ	CC 34
EP2616S	01352525	1,2 – 2,9	1600	0,68	273	286	¼" Ⓞ	CC 34
CON PARADA SUAVE								
EL0410BC-SS-ESD	04654596	0,2 – 0,4	1000	0,40		267	4 mm Ø	CC 24
EL0510BC-SS-ESD	04654604	0,3 – 0,6	1000	0,40		267	4 mm Ø	CC 24
EL0807BC-SS-ESD	04654612	0,5 – 1	700	0,40		267	4 mm Ø	CC 24
EL1007BC-SS-ESD	04654620	0,6 – 1,2	700	0,40		267	4 mm Ø	CC 24
SIN PARADA SUAVE								
EL1007BC-ESD	04654638	0,2 – 1,2	700	0,40		267	¼" Ⓞ	CC 24

Atornilladores eléctricos de par bajo

Controladores para atornilladores de 34 V

N.º ref. EC34ES-1

(EC34US-1 con enchufe para Reino Unido)

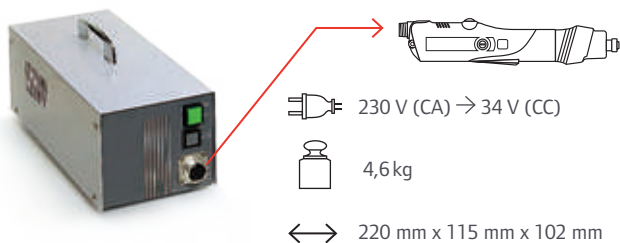

N.º ref. EC34ES-1-CPU

(viene solamente con enchufe europeo)

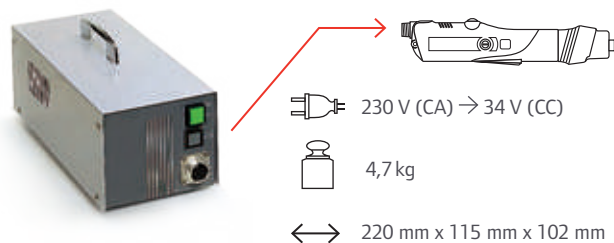

N.º ref. EC34ES-2

(EC34US-2 con enchufe para Reino Unido)

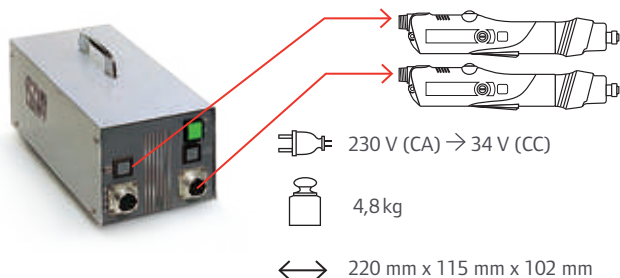

N.º ref. EC34ES-2-CPU

(viene solamente con enchufe europeo)

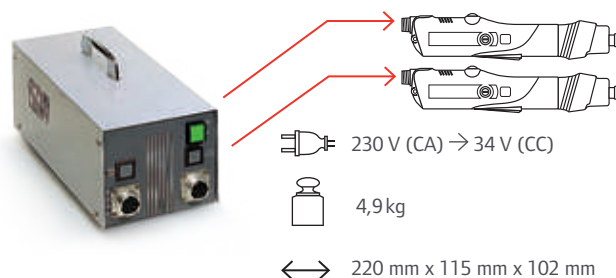

- Trabaje con varios atornilladores (cuatro en este ejemplo).
- Secuencie la selección de atornilladores.
- Programe el cambio de herramientas.
- Cuento los ciclos de apriete.
- Supervise los pares de apriete.



Controladores CPU (34 V) con conector SUB-D15 para PLC

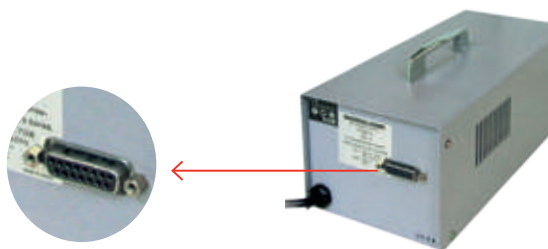

Atornilladores eléctricos de par bajo

Controladores para atornilladores de 24 V

N.º ref. EC24E

(EC24-U con enchufe para Reino Unido)



 Cable de 5 patillas (ref. EL0109B-239)

 230 V (CA) → 24 V (CC)

 2,3 kg

 267 mm x 83 mm x 104 mm

N.º ref. EC24-ESD

(viene solamente con enchufe europeo)



 Cable de 6 patillas (ref. EL0410B-239-ESD)

 230 V (CA) → 24 V (CC)

 2,3 kg

 267 mm x 83 mm x 104 mm

N.º ref. EC24E-CPU

(viene solamente con enchufe europeo)



Controladores CPU (24 V) con conector SUB-D15 para PLC

**No disponible
para modelos ESD**

Atornilladores eléctricos de par bajo

Accesorios



N.º ref. EP4007N-48

Para modelos de 230 V y 34 V

Mango acoplable con empuñadura de pistola: para modelos de arranque por palanca y por empuje.

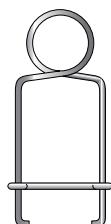

Arcos de suspensión:

Para modelos de 230 V y 34 V

- Vertical: N.º ref. EP4007N-365
- Horizontal: N.º ref. EP4007N-366

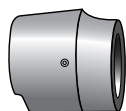

N.º ref. EP4007N-123

Para modelos de 230 V y 34 V

Brida de pequeño perfil: brida de menores dimensiones (de serie en modelos angulares y de pistola).



N.º ref. VDS-511

Para modelos de 230 V y 34 V

Resorte ligero para modelos de par elevado:

0,17 – 0,8 Nm para EP/EL1510E

0,22 – 1 Nm para EP/EL1512K/1525K



N.º ref. EP4007N-516

Para modelos de 230 V y 34 V

Llave de ajuste del par: se utiliza para ajustar el par de forma externa sin tener que retirar la brida.

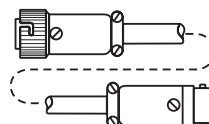

24 V: N.º ref. ES40T-249-2 para controlador

34 V: N.º ref. EC-249-2 para controlador

Para modelos de 34 V y 24 V

Cable de extensión de 2 m de largo: para utilizar entre la herramienta y el controlador.

Atornilladores eléctricos de par bajo

Accesorios

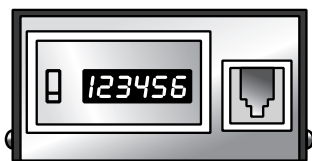

N.º ref. EC24-DC

Para modelos de 34 V y 24 V

Contador digital: disponible por encargo La pantalla digital indica el número de ciclos. Incluye un cable para conectarlo al controlador.

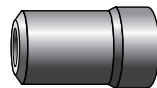

N.º ref. DLW-5300

Para modelos de 24 V

Tapa de ajuste del par para los modelos EL1007E, EL0410E y EL0109E, diseñada para un ajuste invariable del par.

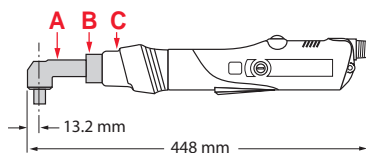

Cabezal angular opcional

	253	255
A	3RL23	3RL25
B	EL4007N255-AHC	
C	ET4007N255-580	

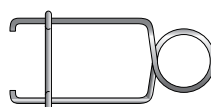

N.º ref. EL0109B-365

Para modelos de 24 V

Soporte vertical para colgar



Taladros neumáticos

Tamaño compacto, ergonomía, excelente relación peso-potencia y durabilidad son los atributos que distinguen a la línea de taladros de Ingersoll Rand para aplicaciones de producción y mantenimiento. Elija de entre nuestra amplia gama de modelos, entre ellos taladros en línea, angulares, con empuñadura de pistola y modulares para satisfacer sus requisitos exactos. Todos los taladros para aplicaciones de producción poseen las mismas características principales, como la doble fila de cojinetes de bolas, que garantiza la precisión de los orificios concéntricos.



Taladros neumáticos

Taladros para producción



De pistola

Transmisión directa 84



Angular

Transmisión directa 85

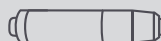

En línea

Transmisión directa 86

Accesorios 87

Taladros de precisión



De pistola

Transmisión directa 88



Angulares

Transmisión directa 89

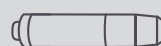

En línea

Transmisión directa 90



Modulares

Transmisión directa 90

Accesorios 91

Taladros neumáticos

Información de la serie

Serie 1

Los taladros de la serie 1 combinan día tras día la calidad y el rendimiento demostrados con la economía en operaciones de taladrado de producción.

- Par crítico: 1,1 – 11,3 Nm
- Velocidad: 600 – 3.800 r. p. m.
- La doble fila de cojinetes de bolas garantiza la precisión de los orificios concéntricos.
- El control de velocidad variable permite un arranque lento y una velocidad alta para taladrar rápidamente
- La excelente relación potencia-peso permite realizar el trabajo con menos cansancio.



1AL1



1LL1

Serie 5

Durabilidad y rendimiento

- Par crítico: 2,30 – 13,6 Nm
- Velocidad: 700 – 4.800 r. p. m.
- La excelente relación potencia-peso permite realizar el trabajo con menos cansancio.



5AJST4-EU



5LK1A4-EU



5LJ1-EU

Serie 7

Durabilidad y rendimiento

- Par crítico: 1,13 – 31,1 Nm
- Velocidad: 600 – 2000 r. p. m.
- La excelente relación potencia-peso permite realizar el trabajo con menos cansancio.



7ANST8-EU



7LM3A43-EU

Taladros neumáticos

Información de la serie

Serie MS

Taladro neumático multifunción

- Par crítico: 11 Nm
- Velocidad: 600 r. p. m.
- Transmisión directa
- Gatillo rápido de inversión de giro



Serie P33

Los taladros de la serie P33 proporcionan precisión insuperable en aplicaciones difíciles-

- Par crítico: 0,6 – 16 Nm
- Velocidad: 660 – 18000 r. p. m.
- El control de velocidad variable permite un arranque lento y una velocidad alta para taladrar rápidamente.
- Motor sin lubricantes
- Empuñadura con cómodo revestimiento Skinsulate



Serie Q2

Los taladros Q2, compactos y ligeros, ofrecen más potencia en un formato más pequeño para realizar el trabajo en menos tiempo.

- Par crítico: 1,1 – 12,8 Nm
- Velocidad: 500 – 5100 r. p. m.
- El diseño ergonómico reduce la fatiga del operario.
- El control de velocidad variable permite un arranque lento y una velocidad alta para taladrar rápidamente.
- La excelente relación potencia-peso permite realizar las tareas con menor cansancio.
- Los números de referencia empiezan por QP, QA o QS, según la forma.







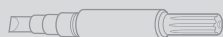
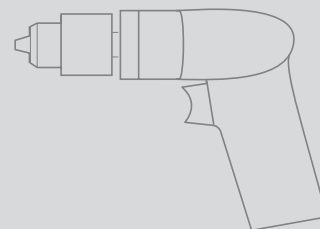

Taladros neumáticos

Taladros para producción | De pistola



Direct drive

Ref.	CCN	 r. p. m.	 r. p. m.	 kg	 mm	 mm	 pulgadas	 mm	 l/s
ARRANQUE POR GATILLO									
1AL1	04725230	2800	1,7	0,65	159	6	3/8 - 24	17	5,2
1P06ST4	04725289	600	11,3	0,68	171	6	3/8 - 24	17	5,2
1P09ST4	04725297	900	7,6	0,68	171	6	3/8 - 24	17	5,2
1P38ST4	4725305	3800	2,3	0,65	159	6	3/8 - 24	17	5,2
5AJST4-EU	01340322	4500	2,3	0,90	173	6	3/8 - 24	21	8
5AKST4-EU	01339993	3000	3,4	0,90	173	6	3/8 - 24	21	8
5ALST4-EU	01338938	2200	4,5	0,90	173	6	3/8 - 24	21	8
5ANST6-EU	01339969	1000	9	1,25	207	10	3/8 - 24	21	8
5RALST6-EU	01341031	2000	4	1	157	10	3/8 - 24	21	8
5RANST8-EU	01341569	900	8	1,40	210	13	3/8 - 24	21	8
7ADST4-EU		2000	1,1	1,02	189	6	3/8 - 24	22	11,7
7AHST4-EU	01340983	6000	3,7	1,05	189	6	3/8 - 24	22	11,7
7AJST4-EU	01338987	4800	4,5	1,05	189	6	3/8 - 24	22	11,7
7AKST6-EU	01340579	3200	6,6	1,08	194	10	3/8 - 24	22	11,7
7ALST6-EU	01338581	2400	8,8	1,22	189	10	3/8 - 24	22	11,7
7AMST6-EU	01338540	1400	14,7	1,33	216	10	3/8 - 24	22	11,7
7ANST8-EU	01338433	900	20,9	1,45	222	13	3/8 - 24	22	11,7
7AQST8-EU	01337914	600	30,5	1,47	222	13	3/8 - 24	22	11,7
MS2206RP5-Q4		600	11	1	190	8	1/4" 	20	9,5
QP051D	01376177	500	9,8	0,70	184	6	3/8 - 24	15	7,5
QP091D	01376136	900	5,8	0,70	184	6	3/8 - 24	15	7,5
QP151D	01376086	1500	3,4	0,70	184	6	3/8 - 24	15	7,5
QP152D	01376052	1500	3,4	0,80	184	10	3/8 - 24	18	7,5
QP201D	01376037	2000	2,8	0,70	184	6	3/8 - 24	15	7,5
QP202D	01376011	2000	2,8	0,80	184	10	3/8 - 24	18	7,5
QP301LD	01379403	3000	1,8	0,65	171	6	3/8 - 24	15	7,5
QP302LD	01379981	3000	1,8	0,75	171	10	3/8 - 24	18	7,5
QP381D	01375914	3800	1,5	0,70	184	6	3/8 - 24	15	7,5
QP511LD	01380062	5100	1,1	0,65	171	6	3/8 - 24	15	7,5
QP512LD	01380088	5100	1,1	0,75	171	10	3/8 - 24	18	7,5

Especificaciones a 6,2 bares (90 psi)

Taladros neumáticos

Taladros para producción | Angulares

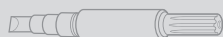
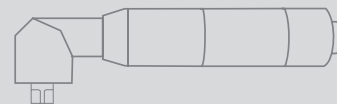

Direct drive

Ref.	CCN	 r. p. m.	 r. p. m.	 kg	 mm	 mm	 pulgadas	 mm	 mm	 l/s
ARRANQUE POR PALANCA										
1LJ1A1	04725271	3700	1,1	0,51	234		¼ - 28		9	5,2
1LL1A1	04725263	2700	1,6	0,51	234		¼ - 28		9	5,2
5LK1A4-EU	01340124	3000	3,5	1	249	5		30	9	8
5LL1A4-EU	01340710	2200	4,5	1	249	5		30	9	8
5LL2A41-EU	01340199	1500	6,8	1,20	239	6		75	14	8
5LN2A43-EU	01340736	700	13,6	1,60	259	10		91	14	8
7LM3A43-EU	01339902	900	21,7	1,79	281	10		99	18	11,7
7LN3A44-EU	01339167	600	31,1	1,90	281	13		105	18	11,7
QA0539D	01390079	500	12,8	0,62	221	4,8		27	10	7,5
QA0559D	01389253	500	12,8	0,62	221		¼ - 28	27	10	7,5
QA0859D	01389261	850	7,6	0,62	221		¼ - 28	27	10	7,5
QA1239D	01390053	1270	4,5	0,62	221	4,8		27	10	7,5
QA2739D	89949267	2700	2,3	0,62	221	4,8		27	10	7,5
QA2759D	01379858	2700	2,3	0,62	221		¼ - 28	27	10	7,5







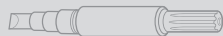

Especificaciones a 6,2 bares (90 psi)

Taladros neumáticos

Taladros para producción | En línea



Direct drive

Ref.	CCN	 r. p. m.	 r. p. m.	 kg	 mm	 mm	 pulgadas	 mm	 l/s
ARRANQUE POR PALANCA									
1LL1	04725248	2800	1,7	0,51	194	6	3/8 - 24	17	5,2
1S30MF4	04725255	3000	1,9	0,54	186	6	3/8 - 24	17	5,2
5LJ1-EU	01340462	4800	2,3	0,90	205	6	3/8 - 24	21	8
5LK1-EU	01340116	3100	3,4	0,90	205	6	3/8 - 24	21	8
5LL1-EU	01340728	2300	4,5	0,90	205	6	3/8 - 24	21	8
5LN3-EU	01340405	1050	9	1,50	238	10	3/8 - 24	21	8
QS151D	01387257	1500	3,8	0,62	205	6	3/8 - 24	15	7,5
QS301D	01387273	3000	1,9	0,62	205	6	3/8 - 24	15	7,5
QS381D	01387281	3800	1,5	0,62	205	6	3/8 - 24	15	7,5
QS511D	01387299	5100	1,2	0,62	205	6	3/8 - 24	15	7,5

Especificaciones a 6,2 bares (90 psi)

Taladros neumáticos

Taladros para producción | Accesorios

Pinzas para taladros angulares Q2

Ø mm	N.º ref.:	Ø mm	N.º ref.:	Ø mm	N.º ref.:	Ø mm	N.º ref.:
1	43497-60	2,1	43497-44	3,5	43497-28	4,9	43497-9
1,05	43497-58	2,2	43497-43	3,6	43497-27	5	43497-8
1,1	43497-57	2,3	43497-42	3,7	43497-25	5,1	43497-7
1,2	43497-56	2,4	43497-40	3,8	43497-24	1/16	43497-161
1,3	43497-55	2,5	43497-38	3,9	43497-23	5/64	43497-162
1,4	43497-54	2,6	43497-37	4	43497-20	3/32	43497-163
1,5	43497-53	2,7	43497-35	4,3	43497-18	7/64	43497-164
1,6	43497-52	2,8	43497-33	4,4	43497-16	1/8	43497-165
1,7	43497-51	2,9	43497-32	4,5	43497-15	9/64	43497-166
1,8	43497-50	3	43497-31	4,6	43497-14	5/32	43497-167
1,9	43497-48	3,2	43497-30	4,7	43497-13	11/64	43497-168
2	43497-45	3,4	43497-29	4,8	43497-11	3/16	43497-169

Pinzas para los modelos 5LL1A4-EU y 5LK1A4-EU

Ø mm	N.º ref.:	Ø mm	N.º ref.:
2	43497-45	5/64	43497-162
2,5	43497-38	3/32	43497-163
3	43497-31	7/64	43497-164
3,5	43497-28	1/8	43497-165
4	43497-20	9/64	43497-166
4,5	43497-15	5/32	43497-167
5	43497-8	11/64	43497-168
1/16	43497-161	3/16	43497-169

P33N Series The New Generation of Modular Drills

When Engineering know-how, state of the art design and ergonomics meet along with quality and new requirements of flexible production: Ingersoll Rand provides you with it's latest P33N generation of precision drills.

The Ingersoll Rand P33N drill range, originates as an evolution from successful P33 drill range, providing the same ideal flexibility, power and durability but with a better tool identification as well as an outstanding new ergonomics.

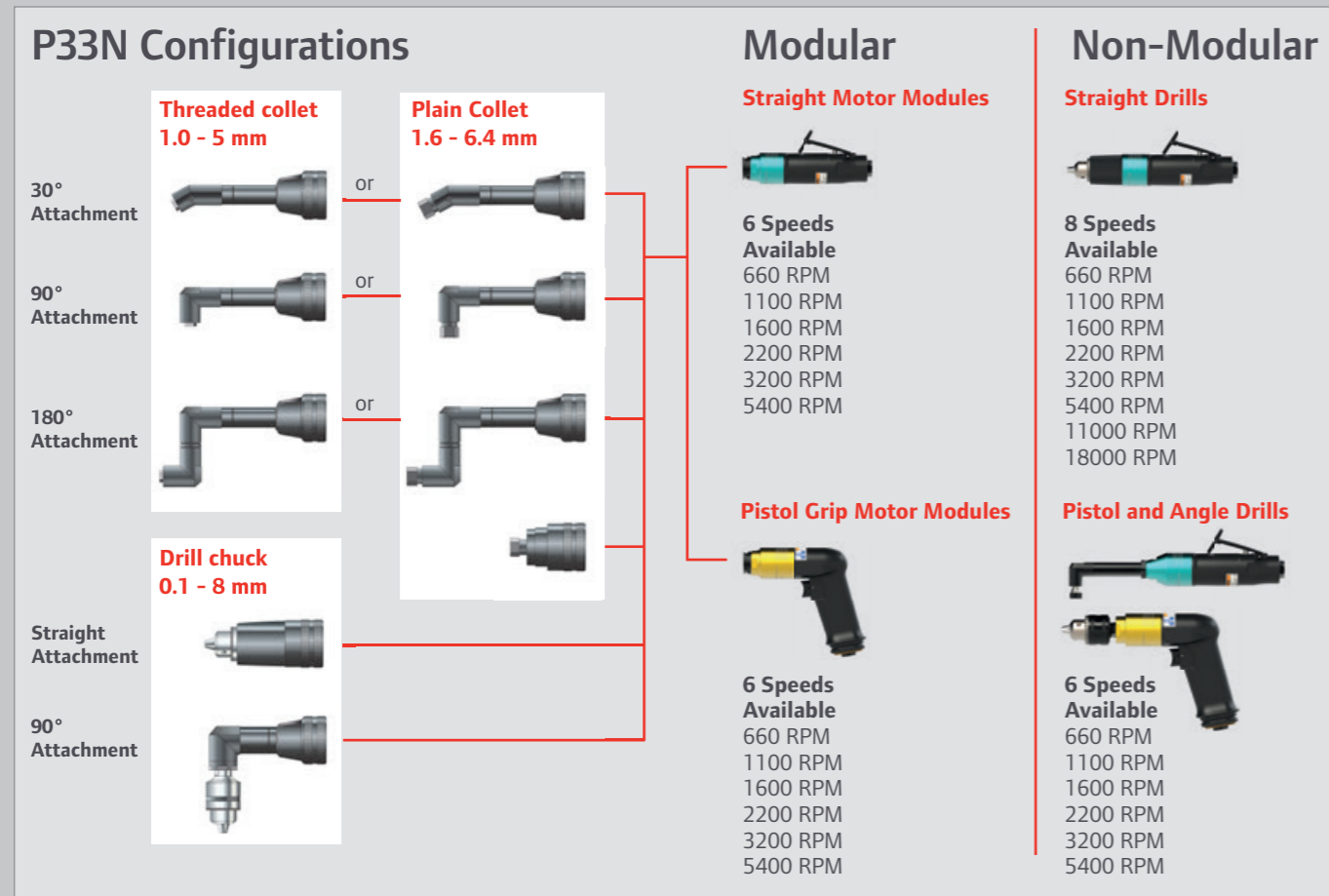

Flexibility and Interchangeability

- One motor 330W (0.44 hp).
- Pistol, straight or Angle version
- Wide range of speeds available, from 660 to 18000 rpms.
- 30°, 90°, 180° angle heads
- R33 attachments are fully compatible with P33N Modular drills.
- P33N is the ideal tool for the multi-task drilling environment, it matches operator needs for accuracy and precise drilling operations according to material and application requirements.

Operator Comfort and Ergonomics

- Lube free motor for a clean working environment.
- Soft touch housing for a more ergonomic grip.
- Quick change motor and attachment to provide end user with fast changeover.

Economic Effectiveness

- Thanks to its flexibility, P33N modular air drills remain your best choice to reduce investment in motor units and attachments
- P33N range share same motor and gears to reduce inventory cost.

Adaptable to Your Application.

From aircraft manufacturing to aerospace maintenance, P33N is designed to offer flexibility and to answer for requirements of precise drilling and reaming of high technology materials for the aerospace industry.

Aircraft assembly

Wings, Cockpit, Fuselage



Helicopter assembly

Tail boom, Cabin door, Cockpit flooring



Aerospace maintenance

Fuselage replacement, Wings repair, Nacelle servicing



Drilling Selection Guide

Material	Velocity m/min	Hole Diameter							
		1/16"	1/8"	3/16"	1/4"	5/16"	3/8"	7/16"	
Steel Alloy (300-400 Brinell)	5-10 Tool recommended	1250-1800 011-016	600-900 006	400-600 006	300-450 //	250-350 //	200-300 //	175-250 //	
Cast Iron (med.-hard)	20-30 Tool recommended	4300-6000 054	2100-3000 022-032	1400-2000 016-022	1000-1500 011-016	850-1200 011	700-1000 006-011	600-900 006	
Mild Steel (0,2-0,3 Carbon)	25-35 Tool recommended	5000-6700 054	2500-3400 032	1600-2300 016-022	1200-1700 016	950-1350 011	800-1150 011	700-1000 011	
Cast Iron (soft) / Plastic	30-45 Tool recommended	6000-9000 054	3000-4500 032	2000-3000 022	1500-2300 016-022	1200-1800 016	1000-1530 011	900-1300 011	
Aluminum / Brass / Bronze	60-100 Tool recommended	12000-18000 110	6000-9000 054	4000-6000 054	3000-4500 032	2400-3700 032	2000-3000 022-032	1700-2600 016-022	
Composite	50-100 Tool recommended	6500-26000 110-180	5400-6500 054	3000-6500 032	2500-4500 032	2000-3700 022-032	1700-3700 022-032	1600-2200 016-022	
Fiberglass / Wood	90-150 Tool recommended	18000-25000 180	9000-12000 110	6000-8200 054	4600-6100 054	3700-4900 032	3000-4000 032	2600-3500 032	

Product description

MODULAR P33N006-DMSL-B 1 2 3 4 5	NON MODULAR P33N006-PSL 1 2 3	NON MODULAR ANGLE P33N032-DASL090P45 1 2 3 4 5	ATTACHMENT R33M090D17P45 1 2 3 4
1 New generation of precision drills P33N	1 New generation of precision drills P33N	1 New generation of precision drills P33N	1 Attachment for Modular drills R33
2 Speed 006, 011, 016, 022, 032, 054	2 Speed 006, 011, 016, 022, 032, 054, 110**, 180**	2 Speed 006, 011, 016, 022, 032, 054	2 Head orientation M000 : straight M030 : 30° M090 : 90° M180 : 180°
3 Tool shape P : Pistol D : Straight	3 Tool shape PSL : Pistol DSL : Straight	3 Tool shape DASL : Angle	3 Angle head diameter blank : straight head D17 : 17mm D25 : 25mm
4 Modular motor MSL		4 Head configurations 030 : 30° 090 : 90° 180 : 180°	4 Collet thread size P45 : 9/32" x 40 P64 : for plain collet F1/4 : 1/4" - 28 UNF F5/16 : 5/16" - 24 UNF F80 : M11x1 P80 : 8mm drill chuck M80 : for plain collet
5 Tool start blank : lever start B : button start*		5 Collet thread size P45 : 9/32" x 40 P64 : for plain collet	

* only available for 3,200 rpm and 5,400 rpm tools

** only available on straight shape

KEY FEATURES



High efficiency gearing

The precision gearing is mounted on precision ball bearings and high resistance bushing in composite material which ensure low vibration and smooth running.

NEW

Speed color coding

All tools have a speed color identification. This provides quick identification and then avoid mistakes when comes select the tool in user toolbox.

Black	18000 rpm
Brown	11000 rpm
Orange	5400 rpm
Blue	3200 rpm
Grey	2200 rpm
White	1600 rpm
Green	1100 rpm
Yellow	660 rpm

NEW

Variable speed control with safety lever

All straight motor modules have a sensitive and progressive throttle for precise control (control by lever as standard). The 3200 and 5400 rpm motor modules are also available with button throttle control.

Modular bevel gear construction

All gearing in the angle head is mounted on ball bearings to ensure perfect alignment and low noise level. One bevel gear is common throughout all heads to reduce spares inventory and to simplify repair.



Lightweight lube-free motor and vanes

High power, high torque air motor. Identical to all models for reduced spares inventory and easy maintenance.

Ergonomics housing

NEW

Softtouch PU Paint prevent from cold metal housing and reduces vibrations while securing grip with minimal grip force. Straight tool has an average diameter of 36mm which provides optimized size for cylindrical grip.

Easy maintenance

Spare part tune up kits is available for simple and efficient maintenance of each tool. For a cost-effective management of a large number of tools, both modular and non-modular P33N drills share 95% of their spare parts.



Chuck guard on DSL & PSL model*

Prevent injuries on user's fingers and offer better support.

**Not provided on 006 and 011 model*

Quick change mechanism

The patented mechanism for attaching and orienting the drill heads is very safe and convenient to use. Attachment change is done in 3 seconds. All new modular drills are compatible with R33 attachments.

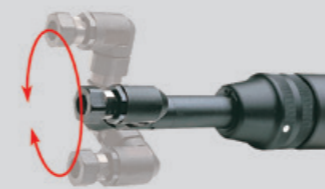

Angle head with 360° rotating head mechanism

Modular drills, PMSL and DMSL allows the head to be located at any of 18 positions, at 20° intervals. Non modular drills DASL, are available in 3 angle configurations : 30°, 90° and 180°. Each angle head can be easily oriented through 360°



Drilling Attachment Spindles

The drilling attachments are available with plain collet, threaded collet or chuck*.

**Only on R33 attachments. Not available on DASL models.*

Air Drills



Precision Drills | Pistol

Ref.	CCN	1 min rpm	MAX Nm rpm	kg	mm	MAX mm	mm	MAX l/s
TRIGGER START								
 P33N006-PSL	53430302	660	16.0	0.95	209	10.0	20	10.0
P33N011-PSL	53430344	1100	9.5	0.95	209	10.0	20	10.0
P33N016-PSL	53430385	1600	6.8	0.95	209	8.0	20	10.0
P33N022-PSL	53430435	2200	4.5	0.80	194	8.0	20	10.0
P33N032-PSL	53430468	3200	3.2	0.80	194	6.0	20	10.0
P33N054-PSL	53430500	5400	1.9	0.80	194	6.0	20	10.0

Precision Drills | Inline



Ref.	CCN	1 min rpm	MAX Nm rpm	kg	mm	MAX mm	mm	MAX l/s
LEVER TO START								
 P33N006-DSL	53430294	660	16.0	0.78	235	10.0	20	10.0
P33N011-DSL	53430336	1100	9.5	0.78	235	10.0	20	10.0
P33N016-DSL	53430377	1600	6.8	0.78	227	8.0	20	10.0
P33N022-DSL	53430419	2200	4.5	0.65	212	8.0	20	10.0
P33N032-DSL	53430450	3200	3.2	0.64	212	6.0	20	10.0
P33N054-DSL	53430492	5400	1.9	0.65	212	6.0	20	10.0
P33N110-DSL	53430526	11000	0.9	0.72	227	6.0	20	10.0
P33N180-DSL	53430542	18000	0.6	0.63	212	6.0	20	10.0

Precision Drills | Angle

Ref.	CCN	1 min rpm	MAX Nm rpm	kg	mm	MAX mm	mm	MAX l/s
WITH 30° ANGLE HEAD								
 P33N006-DASL030P45	53448122	660	16.0	0.80	284	5	20	10.0
P33N006-DASL030P64	53448130	660	16.0	0.81	296	6.4	32	10.0
P33N011-DASL030P45	53448205	1100	9.5	0.80	284	5	20	10.0
P33N011-DASL030P64	53448197	1100	9.5	0.81	296	6.4	32	10.0
P33N016-DASL030P45	53448254	1600	6.8	0.80	284	5	20	10.0
P33N016-DASL030P64	53448262	1600	6.8	0.81	296	6.4	32	10.0
P33N022-DASL030P45	53433934	2200	4.5	0.69	269	5	20	10.0
P33N022-DASL030P64	53448403	2200	4.5	0.70	281	6.4	32	10.0
P33N032-DASL030P45	53434031	3200	3.2	0.69	269	5	20	10.0
P33N032-DASL030P64	53448460	3200	3.2	0.70	281	6.4	32	10.0
P33N054-DASL030P45	53448494	5400	1.9	0.69	269	5	20	10.0
P33N054-DASL030P64	53448502	5400	1.9	0.70	281	6.4	32	10.0
WITH 90° ANGLE HEAD								
 P33N006-DASL090P45	53448148	660	16.0	0.80	277	5	31	10.0
P33N006-DASL090P64	53448155	660	16.0	0.81	277	6.4	43	10.0
P33N011-DASL090P45	53433918	1100	9.5	0.80	277	5	31	10.0
P33N011-DASL090P64	53448221	1100	9.5	0.81	277	6.4	43	10.0
P33N016-DASL090P45	53448288	1600	6.8	0.80	277	5	31	10.0
P33N016-DASL090P64	53448296	1600	6.8	0.81	277	6.4	43	10.0
P33N022-DASL090P45	53433959	2200	4.5	0.70	262	5	31	10.0
P33N022-DASL090P64	53448429	2200	4.5	0.71	262	6.4	43	10.0
P33N032-DASL090P45	53434049	3200	3.2	0.69	262	5	31	10.0
P33N032-DASL090P64	53448478	3200	3.2	0.70	262	6.4	43	10.0
P33N054-DASL090P45	53448510	5400	1.9	0.69	262	5	31	10.0
P33N054-DASL090P64	53448528	5400	1.9	0.70	262	6.4	43	10.0
WITH 180° ANGLE HEAD								
 P33N006-DASL180P45	53448163	660	16.0	0.86	292	5	63	10.0
P33N006-DASL180P64	53448171	660	16.0	0.88	304	6.4	63	10.0
P33N011-DASL180P45	53448239	1100	9.5	0.86	292	5	63	10.0
P33N011-DASL180P64	53448247	1100	9.5	0.88	304	6.4	63	10.0
P33N016-DASL180P45	53448320	1600	6.8	0.86	292	5	63	10.0
P33N016-DASL180P64	53448387	1600	6.8	0.88	304	6.4	63	10.0
P33N022-DASL180P45	53433967	2200	4.5	0.76	277	5	63	10.0
P33N022-DASL180P64	53448437	2200	4.5	0.78	289	6.4	63	10.0
P33N032-DASL180P45	53434189	3200	3.2	0.76	277	5	63	10.0
P33N032-DASL180P64	53448486	3200	3.2	0.78	289	6.4	63	10.0
P33N054-DASL180P45	53448536	5400	1.9	0.76	277	5	63	10.0
P33N054-DASL180P64	53448544	5400	1.9	0.78	289	6.4	63	10.0

Specifications at 6.2 bar (90 psi)

Precision Drills | Motor Modules

Ref.	CCN	1 min rpm	MAX Nm rpm	kg	mm	mm	MAX l/s
BUTTON CONTROL							
 P33N032-DMSL-B	53433892	3200	3.2	0.53	164	20	10.0
P33N054-DMSL-B	53433900	5400	1.9	0.53	164	20	10.0
LEVER CONTROL							
P33N006-DMSL	53430328	660	16	0.63	179	20	10.0
P33N011-DMSL	53430369	1100	9.5	0.63	179	20	10.0
P33N016-DMSL	53430393	1600	6.8	0.63	179	20	10.0
P33N022-DMSL	53430443	2200	4.5	0.53	164	20	10.0
P33N032-DMSL	53430476	3200	3.2	0.53	164	20	10.0
P33N054-DMSL	53430518	5400	1.9	0.53	164	20	10.0
TRIGGER START							
 P33N006-PMSL	53442604	660	16.0	0.82	161	20	10.0
P33N011-PMSL	53442612	1100	9.5	0.82	161	20	10.0
P33N016-PMSL	53442620	1600	6.8	0.82	161	20	10.0
P33N022-PMSL	53442638	2200	4.5	0.71	146	20	10.0
P33N032-PMSL	53442646	3200	3.2	0.70	146	20	10.0
P33N054-PMSL	53442653	5400	1.9	0.70	146	20	10.0

Precision Drills | Modular Drill Attachments

Orientation	Ref.	MAX mm	A mm	B mm	C mm	D mm	kg
straight	R33M000F1/4	8.0	A + 40	—	—	—	0.16
	R33M000F5/16	8.0	A + 40	—	—	—	0.16
	R33M000P64	6.4	A + 42	—	—	—	0.16
	R33M000M80	8.0	A + 81	—	—	—	0.38
30°	R33M030D17F1/4	6.4	A + 118	24.0	18	—	0.24
	R33M030D17P45	5.0	A + 112	19.5	18	—	0.24
	R33M030D17P64	6.4	A + 124	31.5	18	—	0.26
90°	R33M090D17F1/4	6.4	A + 105	36.0	18	—	0.24
	R33M090D17P45	5.0	A + 105	36.0	18	—	0.24
180°	R33M090D17P64	6.4	A + 105	43.5	18	—	0.26
	R33M090D25F1/4	8.0	A + 78	44.0	25	—	0.34
	R33M090D25F5/16	8.0	A + 78	44.0	25	—	0.34
	R33M090D25F80	8.0	A + 78	50.0	25	—	0.36
180°	R33M090D25M80	8.0	A + 81	98.5	30	—	0.54
	R33M090D25P80	8.0	A + 78	54.0	25	—	0.39
	R33M180D17F1/4	6.4	A + 124	64.0	18	36	0.30
180°	R33M180D17P45	5.0	A + 120	64.0	18	32	0.30
	R33M180D17P64	6.4	A + 131	64.0	18	44	0.32
	R33M180D25F1/4	8.0	A + 99	87.5	25	44	0.40
	R33M180D25F5/16	8.0	A + 99	87.5	25	44	0.40
	R33M180D25P80	8.0	A + 109	87.5	25	54	0.45



Precision Drills | Accessories



Collets for P33 angle drills and R33 heads

THREADED COLLETS FOR P45 HEADS					
Ø mm	Ref. No	Ø mm	Ref. No	Ø mm	Ref. No
1.0	120071	3.25	120104	4.2	120110
1.5	120072	3.3	120113	4.5	120078
2.0	120073	3.5	120076	4.6	120111
2.2	120102	3.6	123991	4.7	125784
2.4	120106	3.7	121552	4.8	120112
2.5	120074	3.8	125783	4.9	121553
3.0	120075	3.9	120107	5.0	120079
3.1	120105	4.0	120077		
3.2	120109	4.1	120103		

PLAIN COLLETS FOR P64 HEADS					
Ø mm	Ref. No	Ø mm	Ref. No	Ø mm	Ref. No
1.6	128250	3.4	128259	5.2	128268
1.8	128251	3.6	128260	5.4	128269
2.0	128252	3.8	128261	5.6	128270
2.2	128253	4.0	128262	5.8	128271
2.4	128254	4.2	128263	6.0	128272
2.6	128255	4.4	128264	6.2	128273
2.8	128256	4.6	128265	6.4	128274
3.0	128257	4.8	128266		
3.2	128258	5.0	128267		

Accessories

-  Suspension Ring for Straight Drill
128065
-  Exhaust Pipe Kit
131898 (Uniquely Optional for P33N Straight)
-  Safety Handle
131 899 (Uniquely Optional for P33N Straight)

-  Drill chuck
117269 / Capacity 6mm - 3/8"-24UNF
115313 / Capacity 8mm - 3/8"-24UNF
117311 / Capacity 10mm - 3/8"-24UNF
-  Spanner
120143 / 16mm across flats
121489 / Double sided (closed) : 8mm and 9mm



Taladros neumáticos

Accesorios para taladros

Accesorios comunes para taladros solamente

	Serie Q2	Serie 5	Serie 7	Serie P33
Protección del portabrocas para modelos rectos y de pistola	TRD-A961-S (para 6 mm Ø) TRD-A961 (para 10 mm Ø)	5A-309 (para relación J, K y L)	7AH-K309 (para relación H, J, K y L)	128037 (para 8 mm Ø máx.)
Adaptador de cuadradillo – 3/8"...	R0H-P212-3/8			
Adaptador para puntas de atornillador de cambio rápido - eje de salida hexagonal de rosca 3/8" – 24 x 1/4"	R0H-A925-4			
Portabrocas sin llave – rosca 3/8" – 24 hembra/categoría industrial	CM-116688 (Ø 0 – 6 mm) 125605 (Ø 0 – 8 mm) 116689 (Ø 0 – 10 mm) 123194 (Ø 0 – 13 mm)			
Portabrocas sin llave – rosca 3/8" – 24 hembra/categoría estándar	KC10MM (Ø 0 – 10 mm) KC13MM (Ø 0 – 13 mm)			
Pinzas para rosca de 9/32" – 40	5L1A4-700-G2.4 (Ø 2,4 mm) 5L1A4-700-G3.2 (Ø 3,2 mm) 5L1A4-700-G4.0 (Ø 4 mm) 5L1A4-700-G4.8 (Ø 4,8 mm)		—	—
Palanca de bloqueo automático (solo para modelos rectos)	—	—	—	131655

Portabrocas y llaves para taladros (para repuesto, vienen de serie con los taladros)

	Relación de engranajes	Ø mm		 N.º ref.:	 N.º ref.:
Serie Q2	—	0 – 6	3/8" – 24	R0H-99	R1H-J253
	—	0 – 10	3/8" – 24	6A-99	R0J-J253
Serie 5	J, K, K2, L y L2	0 – 6	3/8" – 24	R0H-99	R1H-J253
	N y N2	0 – 10	3/8" – 24	R1M-99	R1M-J253
	5RA (relación L)	0 – 10	3/8" – 24	R1M-99	R1M-J253
	5RA (relación N)	2 – 13	3/8" – 24	R0K-99	R1T-J253
Serie 7	H y J	0 – 6	3/8" – 24	R00A-99	R00A-J253
	K	0 – 10	3/8" – 24	6A-99	R0J-J253
	L, M y M3	0 – 10	3/8" – 24	R1M-99	R1M-J253
	N, N3 y Q	2 – 13	3/8" – 24	R0K-99	R1T-J253
Serie P33	—	0 – 6	3/8" – 24	117269	117271
	—	0 – 8	3/8" – 24	CM115-313	117271
	—	0 – 10	3/8" – 24	117311	117312



Otras herramientas neumáticas

Las herramientas neumáticas de roscado resultan ideales para el roscado automático y de bajo coste de agujeros en aplicaciones que no exigen una alta precisión. También son excelentes para formación de roscas con peine. Las remachadoras neumáticas permiten controlar de forma fácil y precisa el acelerador de accionamiento progresivo, y el operario puede modificar la potencia durante la tarea sin perder tiempo de trabajo. Las lijadoras neumáticas son compactas y versátiles a la vez que proporcionan una alta precisión.



Otras herramientas neumáticas

Roscadoras neumáticas



De pistola

Transmisión directa

98

Lijadoras neumáticas

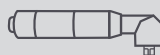

Cabezal angular

Transmisión directa

98

Remachadoras neumáticas



De pistola

Transmisión directa

99



En línea

Transmisión directa

99

Accesorios

100

Otras herramientas neumáticas

Información de la serie

Serie Q2: Roscadoras neumáticas

Roscadoras neumáticas

- Potencia nominal: 0,24 kW
- Nivel acústico: 75 dBa
- Conexión de entrada de aire de la herramienta: NPT de 1/4"
- Diámetro interno mín. de manguera: 6 mm



QP1S10D8

Serie 7: Roscadoras neumáticas

Roscadoras neumáticas

- Conjunto de mango fijo en la serie 7
- Potencia nominal: 0,44 kW
- Nivel acústico: 79 dBa
- Conexión de entrada de aire de la herramienta: NPT de 1/4"
- Diámetro interno mín. de manguera: 8 mm



7RAQT4-EU

Otras herramientas neumáticas

Información de la serie

Serie AVC: Remachadoras neumáticas

Remachadoras neumáticas livianas, precisas y de fácil control

- Retenedor tipo panel para conjuntos de remaches
- Acelerador de accionamiento progresivo en los modelos AVC10A1-EU, AVC12A1-EU y AVC13A1-EU
- Nivel acústico: 94 - 97 dBa
- Conexión de entrada de aire de la herramienta: NPT de 1/4"
- Diámetro interno mín. de manguera: 8 mm



AVC13A1-EU



AVC10A1-EU

Serie PBA: Lijadoras neumáticas

Lijadoras neumáticas

- La POLA15000 viene sin disco.
- Potencia nominal: 0,22 kW
- Nivel acústico: 78 dBa
- Conexión de entrada de aire de la herramienta: BSP de 1/4"
- Diámetro interno mín. de manguera: 13 mm



PBA416









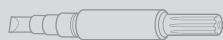
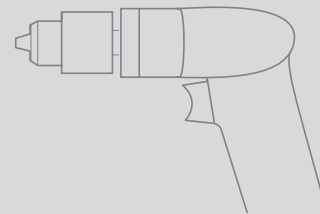

POLA15000

Otras herramientas neumáticas

Roscadoras neumáticas | De pistola



Direct drive





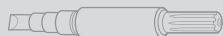
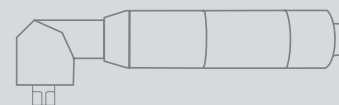

Ref.	 r. p. m.	 Nm	 kg	 mm	 mm	 pulgadas	 mm	 l/s
ARRANQUE POR GATILLO								
QP1S10D8D	1000	5,2	0,85	183	6	Cónica (CM1)	15	7,5
QP1S05D8D	500	9,8	0,85	183	6	Cónica (CM1)	15	7,5
7RAQT4-EU	475	27	1,50	300	13	Cónica (CM1)	22	12,7

Especificaciones a 6,2 bares (90 psi)

Lijadoras neumáticas | Angulares



Direct drive

Ref.	 r. p. m.	 mm	 mm	 mm	 kg	 mm	 l/s
CONTROL MEDIANTE BOTÓN							
PBA416	15000	—	—	475 x 15	1,05	65	9,7
POLA15000	15000	20-30-46-76	6,35	—	0,65	90	9,7

Especificaciones a 6,2 bares (90 psi)

Otras herramientas neumáticas

Remachadoras neumáticas | De pistola

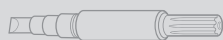
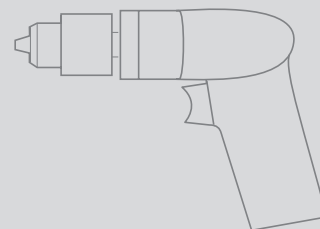

Direct drive

Ref.	Aluminio ∅ mm	Duraluminio e icono de software ∅ mm	mm	kg	mm	∅ mm	1 impacto/min	∅ mm	l/s
ARRANQUE POR GATILLO									
AVC10A1-EU	3	3	143	1,2	48	14	3200	10	6
AVC12A1-EU	5	5	191	1,4	76	14	2100	10	6
AVC13A1-EU	6	6	216	1,5	101	14	1725	10	6
AVC26A1-EU	10	8	276	2,3	152	19	1120	12,7	7

Especificaciones a 6,2 bares (90 psi)

Remachadoras neumáticas | En línea

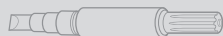

Direct drive

Ref.	Aluminio ∅ mm	Duraluminio e icono de software ∅ mm	mm	kg	mm	∅ mm	1 impacto/min	∅ mm	l/s
ARRANQUE POR GATILLO									
AVC10C1-EU	3	3	172	0,95	48	14	3200	10	6
AVC26B1-EU	10	8	359	3,1	152	14	1120	12,7	7

Especificaciones a 6,2 bares (90 psi)

Remachadoras neumáticas

Accesorios

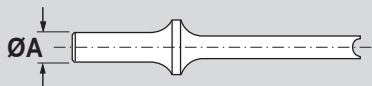

σ A mm	σ mm	Cabeza esférica	Cabeza redonda	Cabeza de gota de sebo	Cabeza semiesférica	Cabeza plana	Cabeza universal
10	1	—	AV1-22B-2	—	—	—	—
10	2	—	—	—	—	—	AV1-22H-3
10	3	AV1-22A-4	AV1-22B-4	AV1-22C-4	—	—	—
10	4	—	—	AV1-22C-5	—	—	AV1-22H-5
10	5	AV1-22A-6	AV1-22B-6	AV1-22C-6	—	AV1-22G-8	AV1-22H-6
10	6	AV1-22A-8	AV1-22B-8	AV1-22C-8	AV1-22F-8	AV1-22G-8	AV1-22H-8
10	8	AV1-22A-10	AV1-22B-10	AV1-22C-10	—	AV1-22G-10	—
12,7	5	—	—	AV24-222C-6	—	—	AV24-222H-6
12,7	6	AV24-222A-8	AV24-222B-8	AV24-222C-8	—	AV24-222G-8	—
12,7	8	AV24-222A-10	AV24-222B-10	—	AV24-222F-10	AV24-222G-10	AV24-222H-10
12,7	9	AV24-222A-12	—	—	—	—	—

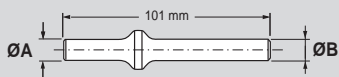

σ A mm	σ B mm	N.º ref.:
10	13	AV1-22S-16
10	16	AV1-22S-20
10	19	AV1-22S-24
10	22	AV1-22S-28

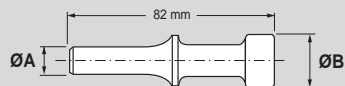

σ A mm	σ B mm	N.º ref.:
12,7	21	AV24-222S-26
12,7	30	AV24-222S-38

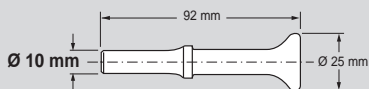

N.º ref. AV1-126D

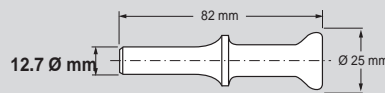

N.º ref. AV24-126D

Lijadoras neumáticas

Accesorios para POLA 15000



Plato de goma para discos autoadhesivos

σ mm	Ref.
20	117155
30	116920
46	116930
76	116940

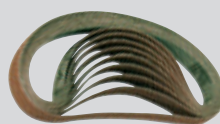

Bandas de lijado de 475 x 15 mm (paquetes de 10 bandas)

Grano	Ref.
36	002300
40	002301
50	002302
60	002303
80	002304
100	002305
120	002306



Pinza de repuesto

σ mm	Ref.
6	122629

Tubería neumática

Accesorios



Filtros – Reguladores – Lubricadores

- Presión máxima de entrada: 17 bar (250 psi)
- Elemento de filtro de 5 μ
- Drenaje automático
- Vaso metálico (con visor en los modelos de 3/8" y 1/2")
- Manómetro
- Margen de temperaturas: de -18 °C a +79 °C



REGULADOR DE FILTRO COM.

UNIDAD COMBINADA (FRL)

Ref.	 pulgadas	 bar l/min	 ml	A mm	B mm	C mm
REGULADOR DE FILTRO COM.						
P39124-624	1/4" NPT	0 – 10	1330	12	157	40
P39234-614	3/8" NPT	0 – 10	2550	38	229	84
P39344-614	1/2" NPT	0 – 10	4870	83	276	70
UNIDAD COMBINADA (F.R.L.)						
C38121-821	1/4" NPT	0 – 10	1300	21/21	120	148
C38231-811	3/8" NPT	0 – 10	2400	30/44	168	168
C38341-811	1/2" NPT	0 – 10	4250	83/110	221	217



Soporte para filtro/regulador (F.R.)

Modelo F.R.	Ref. soporte
P39124-624	104403
P39234-614	104404
P39344-614	104405



Adaptador para tubería modular



Válvula de bloqueo







Abrazadera modular

Modelo F.R.	Modelo F.R.L.	Tamaño puerto adaptador	Ref. adaptador	Ref. válvula de bloqueo	Ref. abrazadera modular
P39124-624	C38121-821	NPT de 1/8"	104474-1	1044390-2	104394
		BSP de 1/8"	104474-A	Tamaño de puerto NPT de 1/4"	
		BSP de 1/4"	104474-B		
P39234-614	C38231-811	NPT de 1/4"	104475-2	104391-3	104395
		BSP de 1/4"	104475-B	(Tamaño de puerto NPT de 3/8")	
		BSP de 3/8"	104475-C		
P39344-614	C38341-811	NPT de 3/8"	104398-3	104392-4	104396
		BSP de 3/8"	104398-C	(Tamaño de puerto NPT de 1/2")	
		BSP de 1/2"	104398-D		







Conjuntos de manguera espiral Supercoil™

Ref.	 mm	 pulgadas	 m	 m	 mm
IR36103	9,5	1/4" NPT	3	2,5	150
IR36203	9,5	1/4" NPT	6	5	340
IR36303	9,5	1/4" NPT	9	8	520
IR36102	9,5	3/8" NPT	3	2,5	150
IR36202	9,5	3/8" NPT	6	5	340
IR36302	9,5	3/8" NPT	9	8	520
IR37102	13	1/2" NPT	3	2,5	165
IR37202	13	1/2" NPT	6	5	380
IR37302	13	1/2" NPT	9	8	580

Herramientas de atornillado y taladrado

Accesorios

Suspensión horizontal (solo para modelos de pistola)	
Suspensión horizontal (solo para modelos angulares)	
Suspensión vertical (solo para modelos rectos y angulares)	
Mango fijo	
Kit para alejar el escape (solo para modelos rectos)	
Manguera de escape	
Empuñadura cómoda (recta y angular/palanca)	
Empuñadura cómoda (atornilladores de pistola)	
Llave de repuesto de ajuste del embrague (modelos con embrague con apagado automático y amortiguado)	
Resortes de embrague/par mín.	

Solo para atornilladores Q2

Piezas diferenciadas por el color: cantonera (para modelos de pistola)	TRP-B-R (naranja) TRP-B-G (verde) TRP-B-B (azul) TRP-B-Y (gris claro)	
Piezas diferenciadas por el color: tapa de ajuste con brida (para modelos rectos)	TRH-40-23-R (naranja) TRH-40-23-G (verde) TRH-40-23-B (azul) TRH-40-23-Y (gris claro)	
Piezas diferenciadas por el color: tapa de ajuste sin brida (para modelos rectos)	TRH-40-24-R (naranja) TRH-40-24-G (verde) TRH-40-24-B (azul) TRH-40-24-Y (gris claro)	

Serie Q2	Serie 41	Serie 5	Serie 7	Serie 8	Serie 9	Serie LD	Serie BALD	Power Pulse	Serie P33
TRP-A365	48934	7RA-A366	7RA-A366	—	—	124621	124621	EQ106P-365	118303
3RA-365 (solo taladros angulares)	48934	6WS-366	6WS-366	8SL-366	9SL-366	—	129851 (excepto 1202)	—	—
7L-365	IR48426-1	5RL-365	7L-365	7L-365	—	118303	118303	EQ106S-365 (excepto 900, 1100, 1900 y 3000)	128065
—	48931	728N-A48 + 5A-49 (x2)	R1A-A48 + 7A-49 (x2)	9SL-48 + 8SL-A60	9SL-48 + 9SL-A60	—	—	—	131899
LG1-K284	—	5L-K184	7L-K284	—	—	—	—	—	—
3RL-284	46490 + 46477	—	—	—	—	—	—	—	—
—	—	CG-5RL (ex- cepto llaves angulares)	CG-7RL CG-7RLD (llaves angulares)	—	—	—	—	—	—
TRP-40-1 (peq.)	—	CG-5RA	CG-7RA	—	—	—	—	—	—
TRH-478	(atornillador estándar)	5C1-416	5C1-416	—	—	124397 (LD12 y LD22)	124397 (BALD12,22)	04352241 (1,5 mm) 04355012 (2 mm) 04352258 (5 mm)	—
—	—	—	—	—	—	124542 1 Nm: LD12 y BALD12, excepto 1202 419300 1,5 Nm: LD22 y BALD22, excepto 203 127407 3 Nm: LD/BALD32	—	—	—

Junta universal Variacor para manguera neumática

Ø A	Ø B	Ref.
NPT de 1/8"	BSP de 1/4"	DV7MN18FB14
NPT de 1/4"	BSP de 1/4"	DV7MN12FB14
BSP de 1/4"	BSP de 1/4"	DV7MB14FB14
BSP de 3/8"	BSP de 3/8"	DV11MB38FB38





Accesorios

Equipos de calibración



EXTT - MEDIDOR DE PAR



EXTA - EQUIPO DE VERIFICACIÓN DEL PAR

Verificador / medidor de par EXTA y EXTT Expert

- Supervisa el par, ángulo, tiempo y número de impulsos
- Lectura en modos de máxima, chasquidos, impulsos o seguimiento
- Guarda hasta 200 lecturas con indicación de tiempo
- Reconocimiento automático de transductores inteligentes
- Siete unidades de medida
- Frecuencias de filtrado seleccionables
- Calibración de herramientas de CC mediante software ICS
- Ajustes seleccionables de ahorro energético
- Varios idiomas seleccionables, entre ellos alemán, español, francés, inglés e italiano

SERIE EXTT — Medidores de par Expert

Modelo	CCN	 Nm	Adaptador reductor*	Kit de servicio de adaptador reductor
EXTT-1	45654043	0,1 – 1	ETT-RA-1	ETT-RA-1-KIT
EXTT-4	45654050	0,4 – 4	ETT-RA-4	ETT-RA-40-KIT
EXTT-12	45654068	1,2 – 12	ETT-RA-12	ETT-RA-12-KIT
EXTT-30	45654076	3 – 30	ETT-RA-30	ETT-RA-30-KIT

* El medidor EXTT viene con adaptador reductor, estuche de transporte, cargador de batería, manuales y un certificado de calibración.

Equipo de verificación del par EXTA:

Diseñado para ser una herramienta portátil y apta para usarla con una amplia variedad de transductores

N.º ref. ⁽¹⁾	CCN	Transductor externo	Transferencia de datos	Reconocimiento automático
EXTA	45654035	Smart de IR o estándar	PC o impresora	SÍ

(1) El verificador de par EXTA viene con estuche de transporte, cargador de batería, manuales y correa para el cuello.

Accesorios

Equipos de calibración

Transductores rotativos

Se utilizan sobre todo para controlar el par dinámico alcanzado durante las operaciones de atornillado llevadas a cabo con herramientas mecánicas o manuales. Con simuladores de juntas adecuados recomendados por Ingersoll Rand, también pueden utilizarse en laboratorios y talleres.

N.º ref. estándar industrial	N.º ref. Transductores inteligentes ⁽¹⁾		Margen de pares (Nm)	Tamaño de salida (in)
	Solo par	Par y ángulo		
TR5H4	TRD5H4	TRDA5H4	0,25 – 5	¼" ⌀
TR20H4	TRD20H4	TRDA20H4	1 – 20	¼" ⌀
TR20S4	TRD20S4	TRDA20S4	1 – 20	¼" ⌀
TR75S6	TRD75S6	TRDA75S6	3,8 – 75	⅜" ⌀
TR180S8	TRD180S8	TRDA180S8	9 – 180	½" ⌀
TR250S12	—	—	12,5 – 250	¾" ⌀
TR500S12	TRD500S12	TRDA500S12	25 – 500	¾" ⌀

(1) TRD y TRDA se reconocen y se calibran automáticamente para su uso inmediato cuando se conectan al EXTA con el cable fijo provisto.



Transductores rotativos TR y TRD



Simulador de juntas JKR

Simuladores de juntas para transductores rotativos

N.º ref.	Par máximo (Nm)	Eje de salida (in)	Eje de entrada (in)	Rosca de junta
JKR20	28	¼	⌀ 13	M8 – 1,25
JKR75	75	⅜	⌀ 19	M12 – 1,75
JKR180	180	½	⌀ 24	M16 – 2
JKR500	500	¾	⌀ 36	M24 – 3

Transductor TS con cable y junta JKS opcionales



Transductor TS

Transductores estáticos

Se usan tanto en talleres como en líneas de montaje. Permiten comprobar rápidamente el ajuste del par en una herramienta motorizada o manual. Para la verificación de herramientas motorizadas se suelen utilizar con un simulador de juntas adecuado. La rigidez de la junta del simulador puede ajustarse fácilmente para imitar las distintas condiciones de la junta, de rígidas a flexibles. Los transductores con kits simuladores de juntas resultan muy útiles en depósitos de herramientas para el ajuste previo de herramientas motorizadas para producción y para medir la capacidad de herramientas motorizadas con distintas rigideces de juntas.

TRANSDUCTOR N.º ref.	Par máximo (Nm)	Tamaño de salida (in)	SIMULADOR DE JUNTAS N.º ref.	Par máximo (Nm)	Eje de entrada (in)	Rosca de junta (mm)	Kit de perno de repuesto para simulador de juntas
TS30S4 ⁽²⁾	1,5 – 30	¼	JKS30	20	⌀ 13	M8 – 1,25	JKS30-BKIT
TS150S6 ⁽²⁾	7,5 – 150	⅜	JKS150	75	⌀ 19	M12 – 1,75	JKS150-BKIT
TS300S8 ⁽²⁾	15 – 300	½	JKS300	180	⌀ 24	M16 – 2	JKS300-BKIT
TS1000S12 ⁽²⁾	50 – 1000	¾	JKS1000	500	⌀ 36	M24 – 3	JKS1000-BKIT

Capacidad de sobrecarga de los transductores: hasta un 110 % de la capacidad total, precisión: 0,3% FSD, estabilidad con desplazamiento cero: 0,1 %/°C, temperatura de funcionamiento: 5 – 40 °C.

(2) También disponible como parte de la serie «inteligente» TSD con cable fijo y reconocimiento y calibración automáticos mediante un equipo de verificación EXTA.

Accesorios

Brazos de reacción montados sobre banco



Equipo estándar

- Cuerpo de aluminio anodizado en el cojinete y el poste cromado
- Equilibrador de muelle de aluminio fundido
- Portaherramientas estándar para herramienta en línea hasta 100 Nm⁽¹⁾
- Abrazaderas de organización de cables para dirigir la manguera neumática o el cable para la herramienta de CC.

Especificaciones

Ref.	MAX Nm Nm	kg	A mm	B mm	C mm
QTA010	10	1,2	380	330	706
QTA020	20	2,3	508	368	808
QTA040	40	3	635	445	1008
QTA100	100	3,6	762	445	1008
QTA150 ⁽²⁾	150	4,5	1321	559	2000

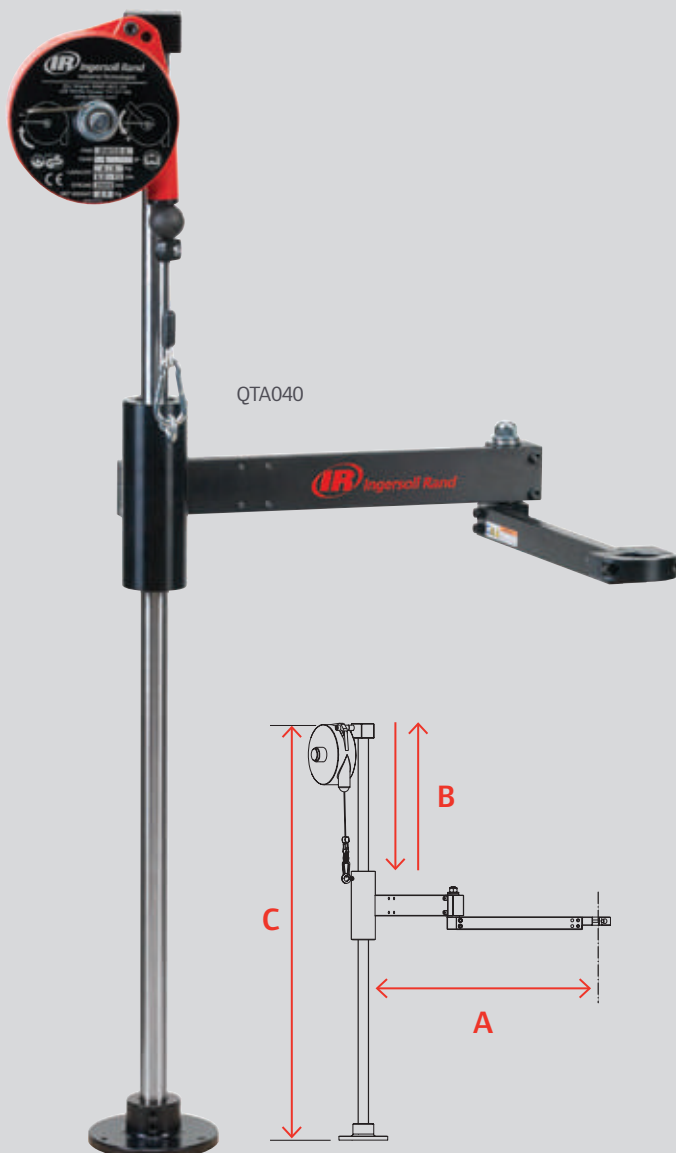

- (1) Véase la página siguiente para ver detalles de otros portaherramientas.
 (2) El QTA150 puede configurarse fácilmente como brazo de par montado sobre banco o en el suelo, y modificar su configuración según lo requiera el trabajo.

Accesorios

Brazos de reacción montados en el suelo

Equipo estándar

- Altura del brazo ajustable en la columna
- Cilindros neumáticos y regulador
- Abrazaderas de organización de cables para dirigir la manguera neumática o el cable para la herramienta de CC
- Tope de seguridad

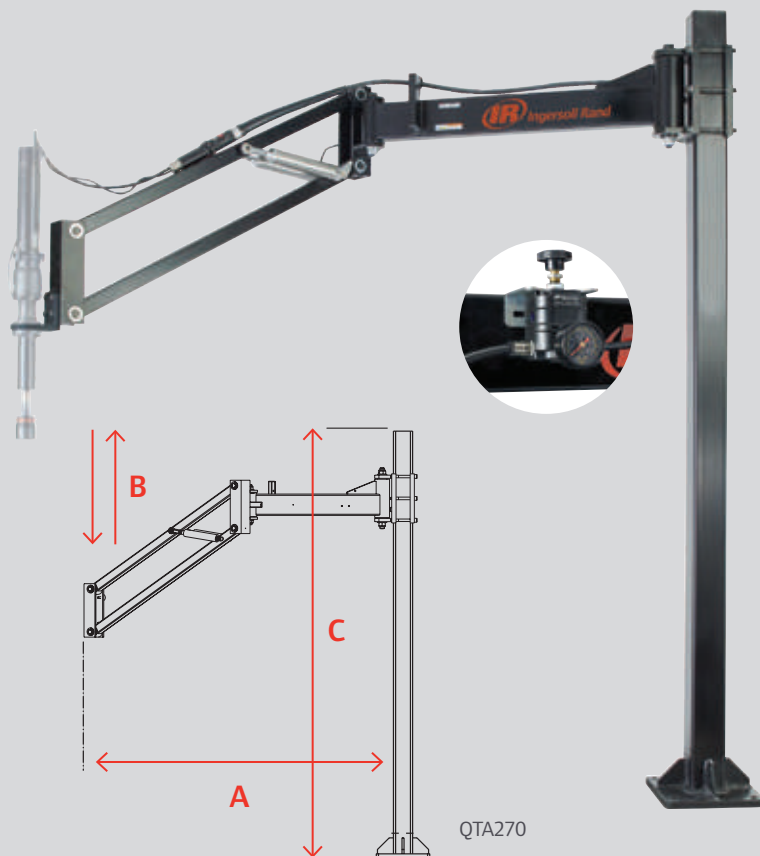

Especificaciones

Ref.	MAX Nm Nm	kg	A mm	B mm	C mm
QTA270	270	10	1524	477	2000
QTA475	475	23	2007	590	2000



Portaherramientas genéricos tipo abrazadera

Tipo	QTA010	QTA020	QTA040	QTA100
En línea (con brazo incluido)	ITC010-1C	ITC040-1C	ITC040-1C	ITC100-1C
1 Ángulo recto	ATC010-1C	ATC040-1C	ATC040-1C	ATC100-1C
2 De pistola	PTC010-1C	PTC040-1C	PTC040-1C	—
3 Giratorio	RTC010-1C	RTC040-1C	RTC040-1C	—
4 NPT de 1/4"	NTC010-1T	—	—	—

Hay portaherramientas genéricos para brazos de hasta 100 Nm (estos brazos vienen de serie con un portaherramientas para herramientas en línea).

Se recomienda el montaje con bridas para herramientas en línea con capacidad de par superior a 40 Nm.

Tenga en cuenta el margen de diámetros de herramienta para los portaherramientas genéricos: QTA010: 25 – 40 mm, QTA020/QTA040/QTA100: 28 – 52 mm.

Accesorios

Portaherramientas para las series QA y QE



Herramientas Ingersoll Rand	QTA010	QTA020	QTA040	QTA100	QTA150	QTA270	QTA475
ARRANQUE POR PALANCA							
QE4	—	CTC040-K1B	CTC040-K1B	—	—	—	—
QE6	—	CTC040-K2B	CTC040-K2B	—	—	—	—
QE8 con  (GEM120-K48)	—	—	—	—	CTC150-K2B	—	—
QE8 con  (brida integrada)	—	—	—	—	CTC150-K3B	CTC270-K3B	—
QE8 230 Nm	—	—	—	—	—	CTC270-K4B	—
QE8 400 Nm	—	—	—	—	—	—	CTC475-K5B
QA4	—	CTC040-K6B	CTC040-K6B	CTC100-K6B	—	—	—
QA4 < 28 Nm y QA6	—	CTC040-K1B	CTC040-K1B	CTC100-K1B	—	—	—
QA4 46 Nm	—	—	—	CTC100-K2B	—	—	—
QA8 < 151 Nm	—	—	CTC040-K1B	CTC100-K1B	CTC150-K2B	—	—
QA8 < 56 Nm	—	—	CTC040-K1B	CTC100-K1B	CTC150-K2B	—	—
QA8 > 150 Nm	—	—	—	CTC100-K2B	CTC150-K3B	CTC270-K3B	—
QA8 > 55 Nm	—	—	—	CTC100-K2B	CTC150-K3B	CTC270-K3B	—
ARRANQUE POR EMPUJE							
QE4	CTC040-K1P	CTC040-K1P	CTC040-K1P	—	—	—	—

Nota: Cada portaherramientas de Ingersoll Rand específico de las series QE o QA que aparece en la lista anterior sirve para herramientas tanto angulares como en línea, pero necesita una caja de engranajes con brida integrada o una brida de montaje complementaria para sujetar el portaherramientas a la herramienta.

Si su herramienta viene con montaje tipo P (con la letra «P» en la referencia del modelo), pida el n.º de referencia 15E4-K48 para cualquier portaherramientas específico de Ingersoll Rand que termine en «1B». Pida el n.º de referencia GEM120-K48 para cualquier portaherramientas específico de Ingersoll Rand que termine en «2B». Pida el n.º de referencia QA4-K48 para cualquier portaherramientas específico de Ingersoll Rand que termine en «6B».



Ingersoll Rand (NYSE:IR) contribuye a la calidad de vida creando entornos confortables, sostenibles y eficientes. Nuestro personal y nuestra familia de marcas (Club Car®, Ingersoll Rand®, Thermo King® y Trane® entre otras) trabajan en estrecha colaboración para mejorar el confort y la calidad del aire en viviendas y todo tipo de edificios, transportar y proteger alimentos y productos perecederos e incrementar la eficacia y la productividad industriales. Somos una empresa global con un capital de 12000 millones de USD comprometida con un mundo de progreso sostenible y resultados duraderos.



www.ingersollrandproducts.com

Distribuido por:

Ingersoll Rand, IR, el logotipo de IR, serie IQv20, serie IQv12, Impactool e Inline son marcas comerciales de Ingersoll Rand, sus empresas subsidiarias o sus filiales. El resto de las marcas comerciales pertenecen a sus respectivos propietarios.

Nada de lo contenido en estas páginas debe interpretarse como extensión de ninguna garantía ni afirmación, expresa o implícita, en relación con el producto descrito en las mismas. Tales garantías u otras condiciones de venta de productos serán conformes a las condiciones de venta estándar de Ingersoll Rand para tales productos, que están disponibles si se solicitan.

La mejora de los productos es un objetivo continuo de Ingersoll Rand. Los diseños y especificaciones están sujetos a cambios sin ningún tipo de obligación ni previo aviso.