



Liftstar and Pullstar Winches

300–7,500 kg (660–16,530 lb)



When Tough Just Isn't Enough

Liftstar and Pullstar Winches 300–7,500 kg (660–16,530 lb)

Since 1924, Ingersoll Rand has built extremely durable and reliable winches and hoists. Designed with premium features and built using rugged cast iron and steel, Ingersoll Rand doesn't take shortcuts and never uses inferior components. Ingersoll Rand Liftstar and Pullstar winches feature a tough, yet compact design that helps them fit almost anywhere. Their low maintenance, highly reliable gear motors have only two moving parts making them virtually maintenance free – even after being stored or inactive for down times. Designed to work in harsh environments, Ingersoll Rand winches are the gold standard. They are often copied but never equaled. Trusted by oilmen, offshore workers, miners and heavy construction crews around the globe, you can count on Ingersoll Rand winches to get the job done.



Liftstar and Pullstar winch features:

- **Rugged cast iron and steel construction** for extreme durability
- **Light weight and compact design** for portability
- **Gear motor** for low maintenance
- **High efficiency planetary gear box** for smooth operation
- **Standard internal muffler** that reduces noise levels
- **Lift and Shift variable speed lever** for precise control and built-in safety
- **Individual load testing** before shipment and delivered with manufacturer's test certificate for quality assurance
- **Easily configured to meet worldwide standards** including ANSI/ASME B30.7 and CE FEM Classification 1 Bm and other 3rd party type approvals
- **Built using nearly a century of experience** and constructed in advanced manufacturing facilities with ISO 9001 quality levels



Ship Building



Mining



Heavy Construction



Marine



Offshore



Onshore



Liftstar Portable Air Winches

300–1,500 kg (660–3,300 lb)

With a tough, yet compact design, Ingersoll Rand Liftstar portable winches are easy to carry. Their rugged gear motors have only two moving parts which makes them virtually maintenance free even after being stored. They are easy to transport wherever you need them and rugged enough to give you the lifting power you need no matter how harsh the conditions.

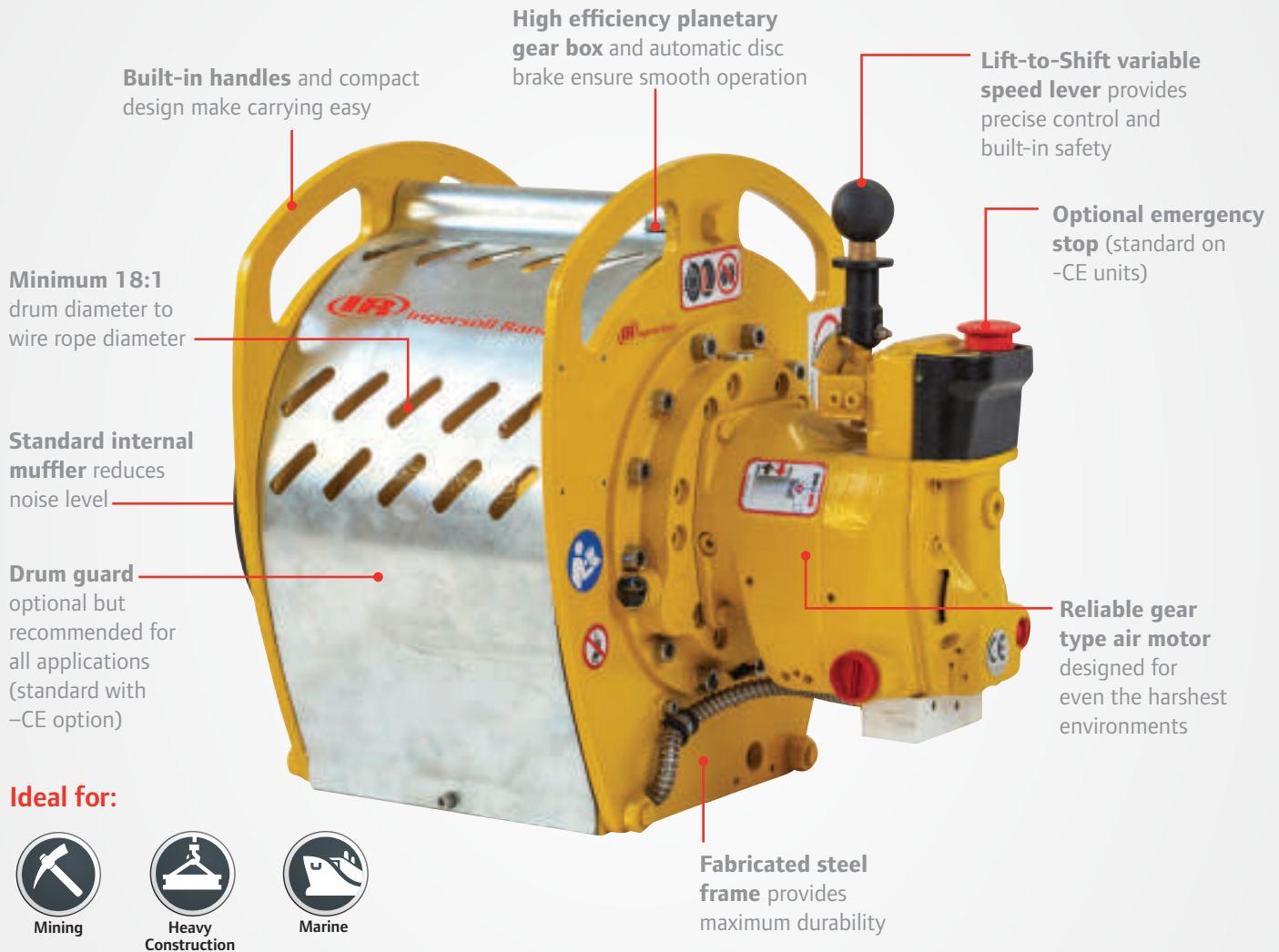

Lifting Ratings at 5:1 design factor and performance at 6.3 bar (90 psi) at air inlet when winch is operating

Model	Line Pull Capacity			Lifting Speed at Top Layer ⁽¹⁾ m/min (fpm)	Air Consumption with Rated Load m ³ /min (ft ³ /min)	Air Volume Needed to Move Rated Load at Top Layer 3 m (10 ft)	Sound Level as per EN 14492-1 dB(A)	Drum Capacity ⁽²⁾		Net Weight kg (lb)
	First Layer kg (lb)	Mid Drum kg (lb)	Top Layer kg (lb)					Max Rope Length m (ft)	Rope Diameter mm (in)	
LS2-300R-L	300 (660)	300 (660)	300 (660)	40 (131)	4 (141)	0.3 (10.8)	92	150 (492)	5 (3/16)	42 (93)
LS2-300RGC-L	300 (660)	300 (660)	300 (660)	40 (131)	4 (141)	0.3 (10.8)	92	307 (1,007)	5 (3/16)	49 (108)
LS2-600R-L	600 (1,320)	600 (1,320)	600 (1,320)	20 (66)	4 (141)	0.6 (21.4)	92	89 (292)	6.5 (1/4)	42 (93)
LS2-600RGC-L	600 (1,320)	600 (1,320)	600 (1,320)	20 (66)	4 (141)	0.6 (21.4)	92	183 (600)	6.5 (1/4)	49 (108)
LS2-1500R-L	1,500 (3,300)	1,500 (3,300)	1,500 (3,300)	10 (32)	4.8 (169)	1.5 (53.0)	90	61 (200)	10 (3/8)	67 (148)
LS2-1500RGC-L	1,500 (3,300)	1,500 (3,300)	1,500 (3,300)	10 (32)	4.8 (169)	1.5 (53.0)	90	128 (420)	10 (3/8)	79 (174)

⁽¹⁾ Top layer speed is based on rated capacity ⁽²⁾ Wire rope is tightly wound with no freeboard.

Pullstar Portable Air Winches

700–2,000 kg (1,540–4,400 lb)

Ingersoll Rand Pullstar portable winches are built for use on horizontal surfaces with little to no incline. Featuring a rugged, compact design Pullstar portable winches can easily be moved to wherever you need them. Pullstar portable winches include a highly reliable gear motor and a free spooling clutch for rapid manual rope pay out.



Ideal for:



Mining



Offshore



Marine

Pulling Ratings at 3.5:1 design factor and performance at 6.3 bar (90 psi) at air inlet when winch is operating										
Model	Line Pull Capacity			Pulling Speed at Top Layer ⁽¹⁾	Air Consumption with Rated Load	Air Volume Needed to Move Rated Load at Top Layer	Sound Level as per EN 14492-1	Drum Capacity ⁽²⁾		Net Weight
	First Layer kg (lb)	Mid Drum kg (lb)	Top Layer kg (lb)					Max Rope Length m (ft)	Rope Diameter mm (in)	
PS2-1000R-L	1,000 (2,200)	850 (1,870)	700 (1,540)	20 (66)	4 (141)	0.6 (21.4)	92	89 (292)	6.5 (1/4)	38 (84)
PS2-1000RGC-L	1,000 (2,200)	850 (1,870)	700 (1,540)	20 (66)	4 (141)	0.6 (21.4)	92	183 (600)	6.5 (1/4)	45 (99)
PS2-2400R-L	2,400 (5,280)	2,150 (4,730)	2,000 (4,400)	6 (20)	4.8 (169)	2.4 (84.8)	90	60 (197)	11 (7/16)	85 (187)
PS2-2400RGC-L	2,400 (5,280)	2,150 (4,730)	2,000 (4,400)	6 (20)	4.8 (169)	2.4 (84.8)	90	127 (417)	11 (7/16)	100 (220)

⁽¹⁾ Top layer speed is based on rated capacity. ⁽²⁾ Wire rope is tightly wound with no freeboard.

Liftstar Heavy Air Winches

2,000–5,000 kg (4,400–11,000 lb)

Ingersoll Rand Liftstar heavy winches incorporate a cast iron and steel design with a rugged gear motor for ultimate durability. They are available with options to suit any need no matter where in the world you operate. Reliable and simple to maintain, Liftstar heavy air winches are specifically built for the types of environments where lesser winches would fail.



Ideal for:

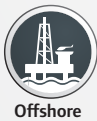

Lifting Ratings at 5:1 design factor and performance at 6.3 bar (90 psi) at air inlet when winch is operating

Model	Line Pull Capacity			Lifting Speed at Top Layer ⁽¹⁾	Air Consumption with Rated Load	Air Volume Needed to Move Rated Load at Top Layer	Sound Level as per EN 14492-1	Drum Capacity ⁽²⁾		Net Weight
	First Layer kg (lb)	Mid Drum kg (lb)	Top Layer kg (lb)					Rope Length m (ft)	Rope Diameter mm (in)	
LS2000R-L	2,800 (6,170)	2,400 (5,290)	2,000 (4,400)	20 (66)	10 (353)	1.5 (53.5)	95	156 (512)	13 (1/2)	230 (507)
LS2000RGC-L	2,800 (6,170)	2,400 (5,290)	2,000 (4,400)	20 (66)	10 (353)	1.5 (53.5)	95	230 (755)	13 (1/2)	283 (624)
LS5000R-L	6,500 (14,330)	5,750 (12,670)	5,000 (11,000)	10 (33)	10 (353)	3.0 (107.0)	87	224 (494)	20 (3/4)	645 (1,422)
LS5000RGC-L	6,500 (14,330)	5,750 (12,670)	5,000 (11,000)	10 (33)	10 (353)	3.0 (107.0)	87	473 (1,043)	20 (3/4)	760 (1,676)

⁽¹⁾ Top layer speed is based on rated capacity. ⁽²⁾ Wire rope is tightly wound with no freeboard.

Pullstar Heavy Air Winches

2,250–7,500 kg (4,950–16,530 kg)

Ingersoll Rand Pullstar heavy winches are designed specifically for pulling applications. They offer a 3.5:1 design factor and come standard with a disengaging clutch to quickly deploy the wire rope. Pullstar heavy winches use a low maintenance, highly reliable gear motor for high torque output and smooth starts and stops. When you combine the gear motor with cast iron and steel construction, Ingersoll Rand Pullstar heavy air winches are one of the most durable pulling winches available.

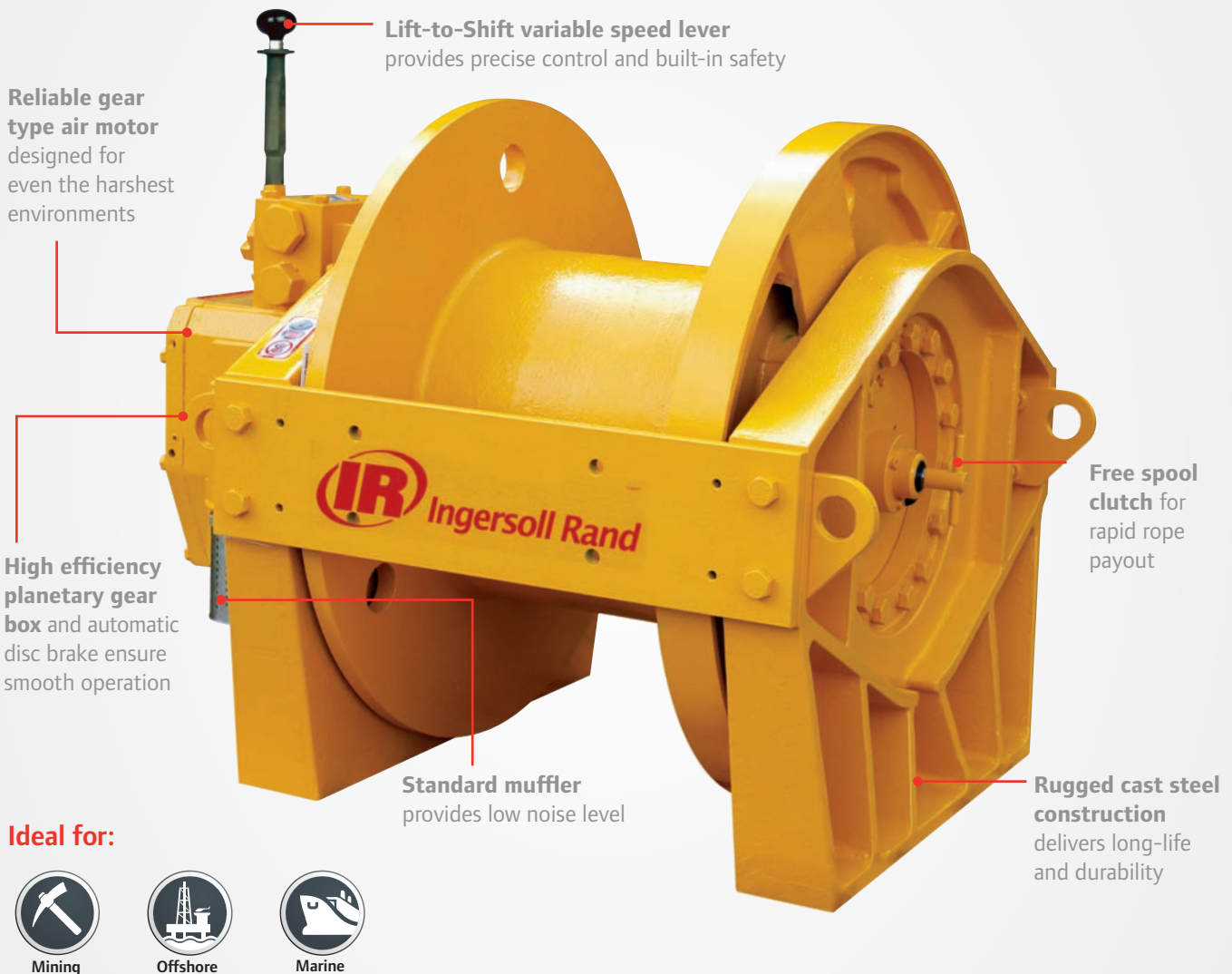

Pulling Ratings at 3.5:1 design factor and performance at 6.3 bar (90 psi) at air inlet when winch is operating										
Model	Line Pull Capacity			Pulling Speed at Top Layer ⁽¹⁾	Air Consumption with Rated Load	Air Volume Needed to Move Rated Load at Top Layer	Sound Level as per EN 14492-1	Drum Capacity ⁽³⁾		Net Weight
	First Layer kg (lb)	Mid Drum kg (lb)	Top Layer kg (lb)					Rope Length m (ft)	Rope Diameter mm (in)	
PS4000R-L	4,000 (8,800)	3,250 (7,150)	2,500 (5,500)	7 (23)	12 (424)	5.1 (184.3)	95	156 (512)	13 (1/2)	225 (496)
PS4000RGC-L ⁽²⁾	3,600 (7,920)	2,925 (6,435)	2,250 (4,950)	8 (25)	12 (424)	4.5 (169.6)	95	230 (755)	13 (1/2)	278 (613)
PS10000R-L	10,000 (22,000)	8,740 (19,265)	7,500 (16,530)	4 (14)	12 (424)	9.0 (302.9)	87	224 (735)	20 (3/4)	640 (1,411)
PS10000RGC-L	10,000 (22,000)	8,740 (19,265)	7,500 (16,530)	4 (14)	12 (424)	9.0 (302.9)	87	473 (1,552)	20 (3/4)	755 (1,664)

⁽¹⁾ Top layer speed is based on rated capacity.

⁽²⁾ For PS4000RGC-L, line pulls are reduced by 10% and line speeds are increased by 10%.

⁽³⁾ Wire rope is tightly wound with no freeboard.

Liftstar/Pullstar Portable Hydraulic Winches

600–700 kg (1,320–1,540 lb)

Ingersoll Rand's hydraulic Liftstar and Pullstar winches offer solid, cast iron and steel construction in a compact package that is easy to deploy wherever you need it. These winches are tough enough to work reliably day in and day out no matter where you put them. They feature dependable orbital hydraulic motors for high efficiency performance. Trusted for years wherever there are extreme lifting or pulling needs, Ingersoll Rand hydraulic winches are the ideal choice.

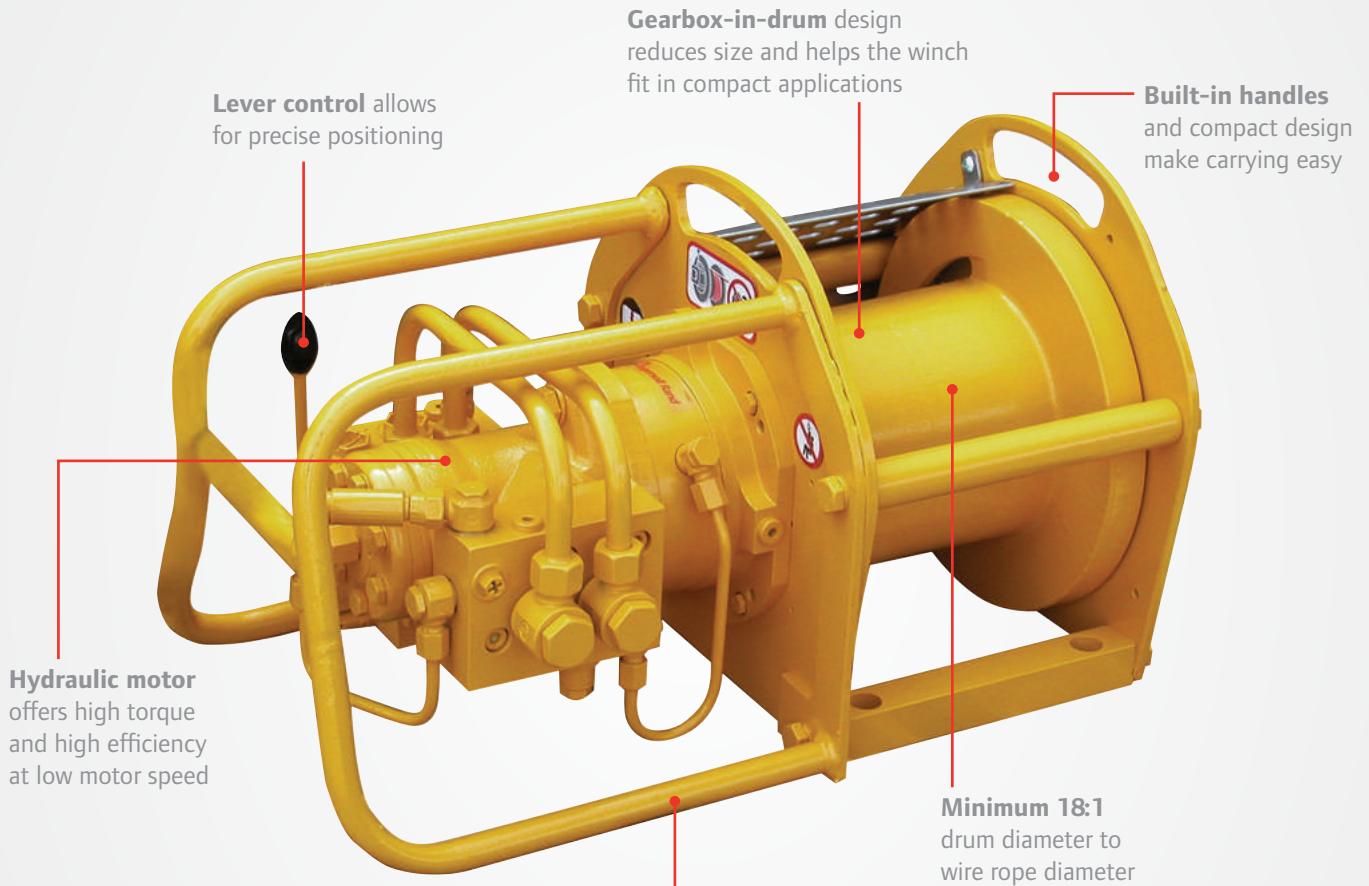

Ideal for:



Onshore



Offshore



Marine

Lifting Ratings at 5:1 design factor and performance at 6.3 bar (90 psi) at air inlet when winch is operating										
Model	Line Pull Capacity			Lifting Speed at top layer	Motor Displacement	Operating Pressure	Rated Flow	Drum Capacity ⁽²⁾		Net Weight
	First Layer kg (lb)	Mid Drum kg (lb)	Top Layer kg (lb)	m/min (fpm)	cm ³ /rev (in ³ /rev)	bar (psi)	l/min (gal/min)	Rope Length m (ft)	Rope Diameter mm (in)	kg (lb)
LS2-600H40-L	800 (1,750)	700 (1,535)	600 (1,320)	20 (66)	40 (2.44)	100 (1,450)	25 (6.6)	89 (292)	6.5 (1/4)	52 (115)
LS2-600H40GC-L	800 (1,750)	700 (1,535)	600 (1,320)	20 (66)	40 (2.44)	100 (1,450)	25 (6.6)	183 (600)	6.5 (1/4)	59 (130)
Pulling Ratings at 3.5:1 design factor and performance at 6.3 bar (90 psi) at air inlet when winch is operating										
PS2-1000H40-L	1,000 (2,200)	850 (1,870)	700 (1,540)	20 (66)	40 (2.44)	120 (1,740)	25 (6.6)	89 (292)	6.5 (1/4)	52 (115)
PS2-1000H40GC-L	1,000 (2,200)	850 (1,870)	700 (1,540)	20 (66)	40 (2.44)	120 (1,740)	25 (6.6)	183 (600)	6.5 (1/4)	59 (130)

⁽¹⁾ Top layer speed is based on rated capacity. ⁽²⁾ Wire rope is tightly wound with no freeboard.

Liftstar Heavy Hydraulic Winches

2,000–5,000 kg (4,400–11,000 lb)

Ingersoll Rand heavy hydraulic Liftstar winches are designed for just about any lifting or application you can throw at them. They feature reliable hydraulic motors for capacities up to 5,000 kg. They can be mounted on a rigid support and operate in any position provided the drum is horizontal. With enclosed gear boxes for protection and cast iron and steel construction for durability, Liftstar heavy hydraulic winches will keep your production operating for years.

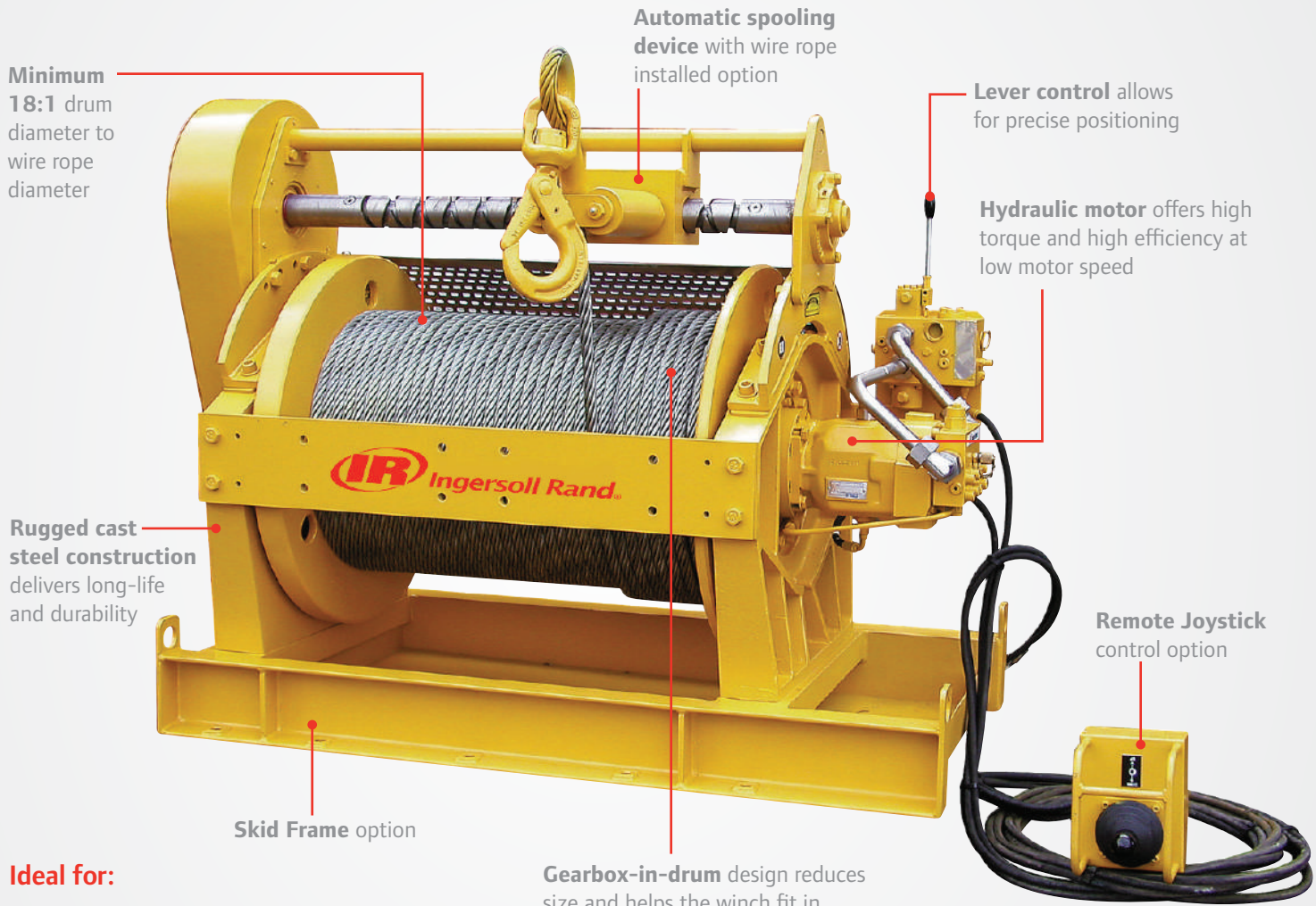

Ideal for:



Onshore



Offshore



Marine

Gearbox-in-drum design reduces size and helps the winch fit in compact applications

Lifting Ratings at 5:1 design factor and performance at 6.3 bar (90 psi) at air inlet when winch is operating										
Model	Line Pull Capacity			Lifting Speed at Top Layer	Motor Displacement	Operating Pressure	Rated Flow	Drum Capacity ⁽²⁾		Net Weight
	First Layer kg (lb)	Mid Drum kg (lb)	Top Layer kg (lb)	m/min (fpm)	m ³ /rev (in ³ /rev)	bar (psi)	l/min (gal/min)	Rope Length m (ft)	Rope Diameter mm (in)	kg (lb)
LS2000H30-L	2,800 (6,200)	2,400 (5,300)	2,000 (4,400)	30 (98)	30 (1.80)	150 (2,180)	65 (17.2)	156 (512)	13 (1/2)	300 (661)
LS2000H30GC-L	2,800 (6,200)	2,400 (5,300)	2,000 (4,400)	30 (98)	30 (1.80)	150 (2,180)	65 (17.2)	313 (1,026)	13 (1/2)	353 (778)
LS5000H75-L	6,500 (14,330)	5,750 (12,665)	5,000 (11,000)	30 (98)	75 (4.60)	150 (2,180)	142 (37.5)	219 (718)	20 (3/4)	730 (1,609)
LS5000H75GC-L	6,500 (14,330)	5,750 (12,665)	5,000 (11,000)	30 (98)	75 (4.60)	150 (2,180)	142 (37.5)	463 (1,519)	20 (3/4)	987 (2,176)

⁽¹⁾ Top layer speed is based on rated capacity.
⁽²⁾ Wire rope is tightly wound with no freeboard.

Pullstar Heavy Hydraulic Winches

2,930–7,000 kg (6,440–15,430 lb)

Ingersoll Rand heavy hydraulic Pullstar winches are designed for pulling. With reliable hydraulic motors and a solid steel construction Pullstar winches are ideally suited for harsh conditions. Whatever your pulling needs, Ingersoll Rand heavy hydraulic winches are the perfect solution.

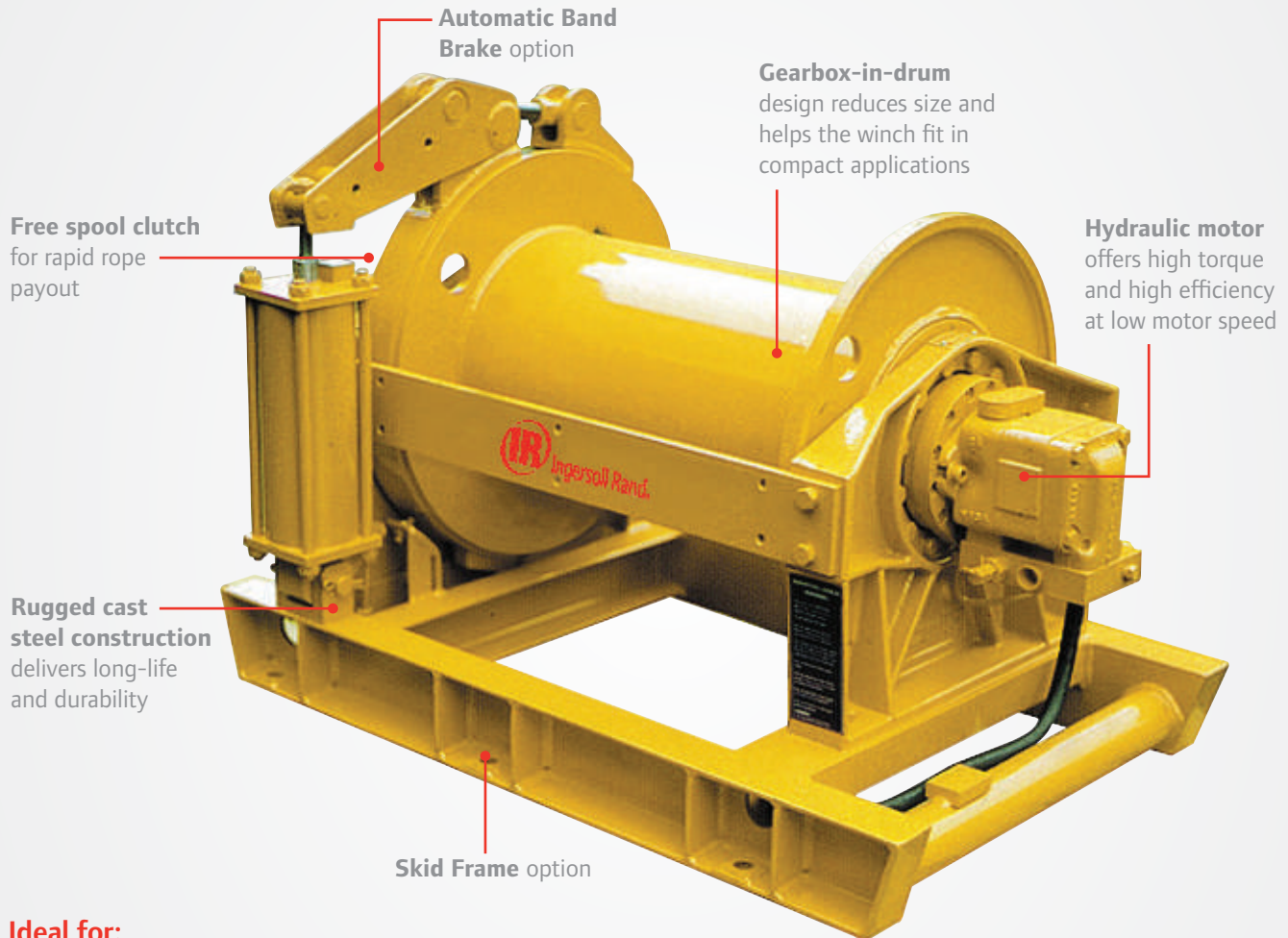

Ideal for:



Mining



Offshore



Marine

Pulling Ratings at 3.5:1 design factor and performance at 6.3 bar (90 psi) at air inlet when winch is operating

Model	Line Pull Capacity			Lifting Speed at top layer m/min (fpm)	Motor Displacement m ³ /rev (in ³ /rev)	Operating Pressure bar (psi)	Rated Flow l/min (gal/min)	Drum Capacity ⁽²⁾		Net Weight kg (lb)
	First Layer kg (lb)	Mid Drum kg (lb)	Top Layer kg (lb)					Rope Length m (ft)	Rope Diameter mm (in)	
PS4000H30-L	4,000 (8,800)	3,465 (7,620)	2,930 (6,440)	20 (66)	30 (1.80)	180 (2,610)	40 (10.6)	156 (512)	13 (1/2)	210 (463)
PS4000H30GC-L	4,000 (8,800)	3,465 (7,620)	2,930 (6,440)	20 (66)	30 (1.80)	180 (2,610)	40 (10.6)	313 (1,026)	13 (1/2)	235 (518)
PS10000H75-L	10,000 (22,000)	8,300 (18,290)	7,000 (15,430)	13 (43)	75 (4.60)	220 (3,190)	75 (19.8)	219 (718)	20 (3/4)	550 (1,213)
PS10000H75GC-L	10,000 (22,000)	8,300 (18,290)	7,000 (15,430)	13 (43)	75 (4.60)	220 (3,190)	75 (19.8)	463 (1,519)	20 (3/4)	615 (1,356)

⁽¹⁾ Top layer speed is based on rated capacity.

⁽²⁾ Wire rope is tightly wound with no freeboard.

A Variety of Options



Drum guard

- Drum guard for non-CE models
- Airline accessories



Emergency stop

- Material traceability certificates on main load bearing parts
- Marine paint finish
- Witness test

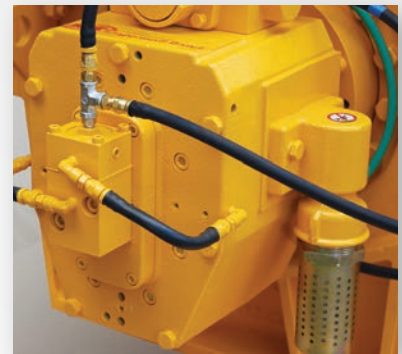

Overload protection

- CE compliance with European Machinery Directive
- Estop, overload protection and Drum guard all part of CE option

Special Orders



A significant portion of our business is providing customized solutions for specific applications. We recognize that not all jobs are created equal and that the most cost-effective solutions may not be in an off-the-shelf item. We've designed and manufactured winches and hoists for applications as simple as moving bags of lettuce, to as intricate as installing critical payloads on space vehicles, including high capacity loads 100 tons and above.

- Design for custom capacities
- Custom control systems
- Custom product modifications
- Witness testing and complete certification to most global standards
- Full data package with CAD drawings
- Dedicated project management for your project from conception to delivery
- Onsite services available including presale and evaluation



A Tradition of Proven Reliability, Efficiency and Productivity



No matter where you are located, Ingersoll Rand is committed to serving and providing you with the necessary information with regard to our products and services. Our world-wide network of distributors, certified technicians and engineers are a telephone call away — ready to support you with innovative and cost-effective solutions that will keep your business running at peak performance.

Global Parts and Services

Ingersoll Rand winches are built to last in even the harshest conditions. We are committed to helping you keep your operation running, no matter where your facility is located. We offer a full range of parts and accessories. Plus Ingersoll Rand's global network of factory trained and authorized technicians can install, repair, test and maintain any winch. Service capabilities include:

- Load test and recertifications
- System inspections
- Equipment refurbishments
- Installation and start-up assistance
- Inspector and operator training
- Service and repair

For More Information



www.ingersollrandproducts.com/lifting



lifting@irco.com



Ingersoll Rand (NYSE:IR) advances the quality of life by creating comfortable, sustainable and efficient environments. Our people and our family of brands—including Club Car®, Ingersoll Rand®, Thermo King® and Trane®—work together to enhance the quality and comfort of air in homes and buildings; transport and protect food and perishables; and increase industrial productivity and efficiency. We are a \$12 billion global business committed to a world of sustainable progress and enduring results.



www.ingersollrandproducts.com

Distributed by:

Ingersoll Rand, IR, the IR logo are trademarks of Ingersoll Rand, its subsidiaries and/or affiliates. All other trademarks are the property of their respective owners.

Unless otherwise noted this equipment is not designed for transporting people or lifting loads over people. It is the user's responsibility to determine the suitability of this product for any particular use and to check compliance with applicable regulations. Before installation, see maintenance and operations manual for additional warnings and precautions.

Nothing contained on these pages is intended to extend any warranty or representation, expressed or implied, regarding the product described herein. Any such warranties or other terms and conditions of sale of products shall be in accordance with Ingersoll Rand's standard terms and conditions of sale for such products, which are available upon request.

Product improvement is a continuing goal at Ingersoll Rand. Designs and specifications are subject to change without notice or obligation.



MR150 Man Rider[®] Winch

150 kg (330 lb)



Ideal for:



Onshore



Offshore



Subsea

MR150 Man Rider® Winch

150 kg (330 lb)



Since 1924, Ingersoll Rand has been building extremely durable and reliable hoists and winches. Designed to work in harsh environments and built using rugged steel and stainless steel Ingersoll Rand doesn't take shortcuts and never uses inferior components. Ingersoll Rand MR150 Man Rider® winches are specifically designed to minimize the risks of lifting people. They meet or exceed strict safe-lifting standards and include features like emergency lowering, slack line prevention and redundant braking systems to help ensure the safety of workers. Ingersoll Rand pioneered the development of Man Rider winches and has provided thousands of them to drilling companies

around the world in the most extreme environments. This experience is built into every Man Rider winch we sell. Trust Ingersoll Rand MR150 Man Rider winches to help you protect your most important asset, your people.

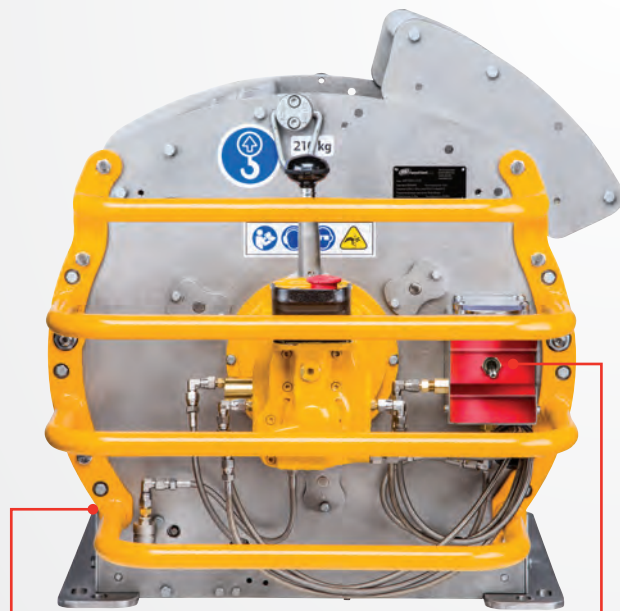

Automatic Multi-Disc Brake and Automatic Drum Brake provide the safety of redundant braking systems

Emergency Lowering System standard integrated system lowers a rider in case of power failure

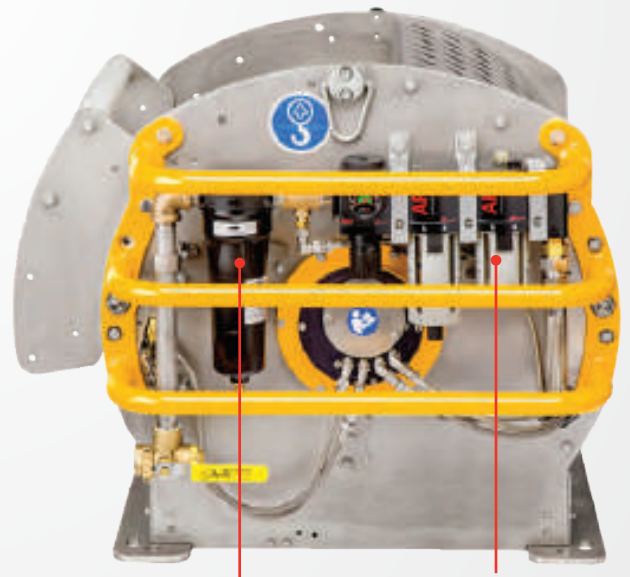

Integrated Water Separator helps protect the motor from moisture

Integrated Filter, Regulator and Lubricator provide clean air to extend the winch's operational life

Designed for Performance in Any Environment

MR150 Man Rider® Standard Features

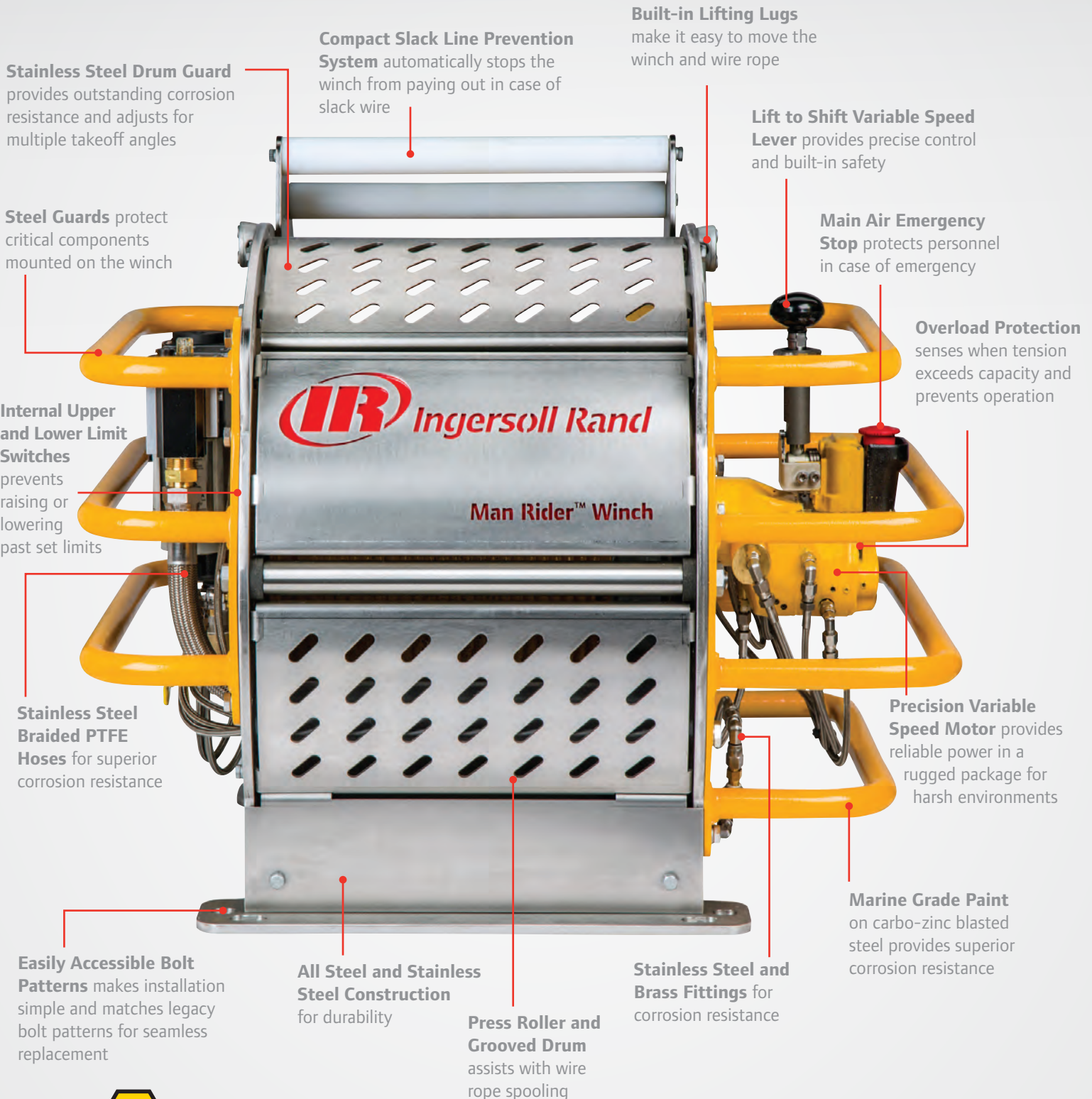

Standard compliance with EU and ATEX Zone 1 directives

Built with Experience You Can Trust



Ingersoll Rand MR150 Man Rider® winches leverage the solid foundation of our legacy Man Rider products and incorporate additional features to increase their safety and durability. MR150s are built to survive where other winches cannot. The MR150 Man Rider has a stainless steel frame and drum guard for enhanced corrosion resistance. All the fittings are brass and stainless steel and hoses are made of braided stainless steel and PTFE to provide long lasting durability. MR150 Man Rider winches help protect operators and riders with dual braking systems, internal upper and lower limit

switches, an integrated emergency lowering system, and slack line prevention system. The MR150 is also designed to meet the latest regulations including CE and ATEX and is available with ABS and DNV type approvals. Ingersoll Rand Man Rider winches work wherever you do. Built with decades of experience, you can count on Ingersoll Rand MR150 Man Rider winches wherever you need to lift or lower people.

The Importance of Using a Man Rider® Winch

Why should you use an Ingersoll Rand Man Rider® Winch instead of a standard winch to lift and lower people on an oil rig? In one word, safety. Deaths and serious injuries caused by falls are common in the oil and gas industry. The numbers speak for themselves:

- 186 lost time or disabling falls to lower levels in the Alberta, Canada upstream oil and gas industry.¹
- 7% of US² and 9% of Middle East/African³ oil worker fatalities caused by falls from higher to lower levels.
- 41 serious injuries attributed to falls from height with 1 fatality in the North Sea.⁴



Ingersoll Rand Man Rider winches provide safety features that reduce the risk of these types of incidents. From integrated limit switches that prevent raising or lowering a person past set limits, to dual braking systems, to a slack arm prevention system that automatically stops wire rope from being paid out in case of obstruction, Ingersoll Rand Man Rider winches combine all the features you need to comply with onshore and offshore regulations for personnel lifting. But even more importantly, Ingersoll Rand Man Rider winches help protect the one piece of critical equipment on your rig that can never be replaced – your people.

¹ Occupational Injuries and Diseases in Alberta 2010, Worksafe Alberta

² U.S. Centers for Disease Control, 2003-2006

³ International Association of Oil & Gas Producers, 2009

⁴ Annual Offshore Statistics, UK Health and Safety Executive, 2014

MR150 Aftermarket Parts And Service Support

In the challenging environments where Ingersoll Rand Man Rider MR150 winches are used, maintenance and serviceability are critical. That's why the MR150 Man Rider winch was designed to be easy to service and repair. The MR150 Man Rider winch features interchangeable drum guard panels, easily accessible components and an Aftermarket Support organization ready to support you with a range of services and readily available spare parts. Ingersoll Rand helps to keep your investment operating with the following services:

EnCompass Service Program – EnCompass Man Rider Authorized Service Centers are specially trained and qualified to provide EnCompass Inspections and EnCompass Service & Certifications to ensure your Man Rider winch is in premium condition and certified for safe operation.



Aftermarket Spare Parts Offering – Ingersoll Rand provides a complete offering of spare parts and service kits to assist in the rapid repair or refurbishment of your Man Rider winch.

Service Guidance – Ingersoll Rand takes the guess-work out of determining when to service and repair your Man Rider winches with easy-to-use service interval guides that help keep your MR150 Man Rider winch operating at peak performance.

Training – Man Rider winches are critical pieces of equipment that get used every day. Ingersoll Rand provides training in proper use and maintenance to help keep your operation running efficiently and your people safe.

Global Parts and Service



Ingersoll Rand winches are built to last in even the harshest conditions. We are committed to helping you keep your operation running, no matter where your facility is located. We offer a full range of parts and accessories. Plus Ingersoll Rand's global network of factory trained and authorized technicians can install, repair, test and maintain any winch. Service capabilities include:

- Load test and recertifications
- Installation and start-up assistance
- System inspections
- Inspector and operator training
- Equipment refurbishments
- Service and repair

A Tradition of Proven Reliability, Efficiency and Productivity



No matter where you are located, Ingersoll Rand is committed to serving and providing you with the necessary information with regard to our products and services. Our world-wide network of distributors, certified technicians and engineers are a telephone call away — ready to support you with innovative and cost-effective solutions that will keep your business running at peak performance.

Special Orders



Ingersoll Rand can provide customized solutions for your application. Whether you need to move specialized or high capacity loads or have custom control requirements, we can build the right solution for you. Ingersoll Rand's global account management team, dedicated project managers and engineering teams are focused exclusively on high capacity hoists and winches. From evaluation to installation and beyond, contact us to build your custom solution today.

- Design for custom capacities
- Custom control systems
- Custom product modifications
- Witness testing and complete certification to any global standard
- Full engineering capabilities including data packages and CAD drawings
- Global Account Management and dedicated project management teams
- Onsite services available including presale evaluation, installation and maintenance

For More Information



www.ingersollrandproducts.com/ManRider



lifting@irco.com

Performance and Dimensions

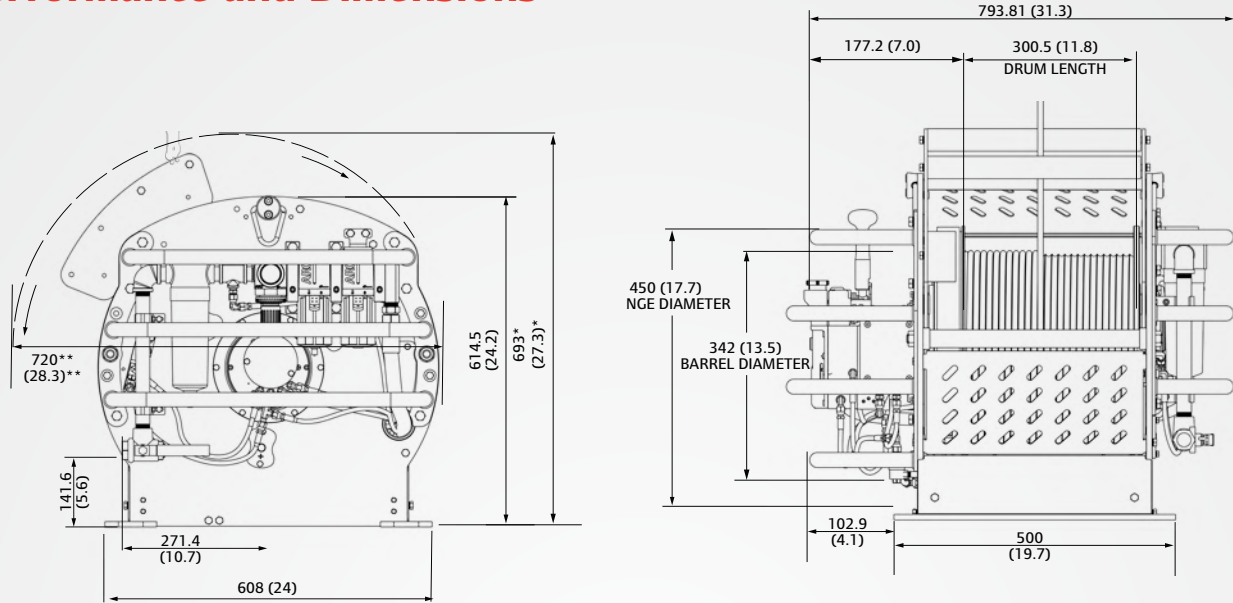

* Maximum height with Slack Arm Prevention System in highest position
 ** Maximum depth with Slack Arm Prevention System in lowest position

Dimensions shown in mm and (in). Standard bolt pattern is compatible with Ingersoll Rand FA150, LS150 and LS2-150 winches.

General Performance and Characteristics at 90 psi (6.2 bar) inlet pressure								
Motor Type	Rated Capacity at Top Layer		Line Speed m/min (fpm)	Max. Rope Storage Capacity 5 layers (w/10 mm rope) m (ft)	Working Rope Storage Capacity 2nd Layer (w/10 mm rope) m (ft)	Drum Length mm (in)	Air Consumption with Rated Load m ³ /min (ft ³ /min)	Net Weight kg (lb)
	kg (lb)	2nd Layer						
MR150K Gear Air Motor	150 (330)	30 (98)	180 (591)	55 (180)	300 (11.8)	2.5 (88)	210 (465)	

How to Order

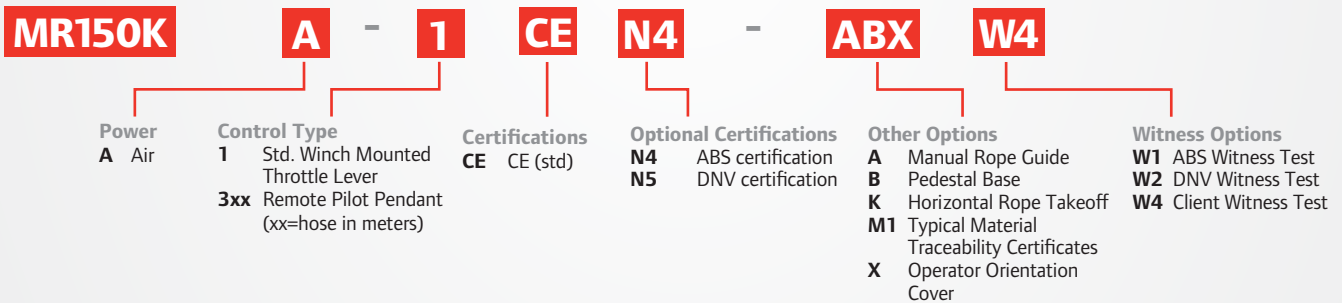

A Variety of Options



Remote Pilot Pendant
Ergonomic pilot pendant provides remote raising, lowering and emergency stop features.



Pedestal Base
Raises the MR150 off the rig floor. Includes pre-drilled bolt holes which match our legacy Man Rider products for securing to the rig floor.

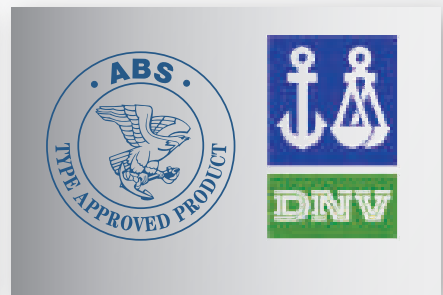

Certification and Witness Options
Certifications and witness testing options to meet the latest regulations from ABS, DNV and others are available.



Ingersoll Rand (NYSE:IR) advances the quality of life by creating comfortable, sustainable and efficient environments. Our people and our family of brands—including Club Car®, Ingersoll Rand®, Thermo King® and Trane®—work together to enhance the quality and comfort of air in homes and buildings; transport and protect food and perishables; and increase industrial productivity and efficiency. We are a \$12 billion global business committed to a world of sustainable progress and enduring results.



www.ingersollrandproducts.com

Distributed by:

Ingersoll Rand, IR, the IR logo are trademarks of Ingersoll Rand, its subsidiaries and/or affiliates. All other trademarks are the property of their respective owners.

Unless otherwise noted this equipment is not designed for transporting people or lifting loads over people. It is the user's responsibility to determine the suitability of this product for any particular use and to check compliance with applicable regulations. Before installation, see maintenance and operations manual for additional warnings and precautions.

Nothing contained on these pages is intended to extend any warranty or representation, expressed or implied, regarding the product described herein. Any such warranties or other terms and conditions of sale of products shall be in accordance with Ingersoll Rand's standard terms and conditions of sale for such products, which are available upon request.

Product improvement is a continuing goal at Ingersoll Rand. Designs and specifications are subject to change without notice or obligation.